

2

Humidity sensors

HYGRASGARD®

Humidity controllers and hygrostats

HYGRASREG®



HYGRASGARD®

PORTFOLIO

- Duct, outdoor, room, and pendulum room humidity sensors
- Dew point and condensation control switches
- Combined versions as humidity and temperature sensors
- On-wall and in-wall installation versions

FEATURES

- With active and/or passive output
- Measuring ranges from 0% to 100% r.H.
- Protection type from IP20 to IP65
- Accuracy up to 2% r.H.
- Enclosure made of glass-globe-reinforced polyamide with quick-locking screws

HYGRASREG®

PORTFOLIO

- Room and duct hygrostats for controlled humidifying and dehumidifying
- Combined versions as room hygro-thermostats

FEATURES

- One- and two-step
- Setting ranges from 25% to 100% r.H.
- With or without display
- Accuracy up to 3% r.H.
- Room humidity controllers for on-wall and in-wall flush box installation

FIELDS OF APPLICATION

- Refrigeration, air conditioning, ventilation, and clean room technology
- Food and pharmaceutical industry
- Hospitals, production halls, and museums
- Laboratories, offices, computer rooms, and control cabinets
- Greenhouses and meteorology

KFF/KFTF including mounting flange AFF/AFTF

Duct respectively on-wall humidity and temperature sensors
calibrateable, with active/passive output



KFF/KFTF

APPLICATION:

For HVAC sector, accuracy 3% r.H.

The calibrateable humidity/temperature sensor measures the relative humidity and temperature of air and other non-aggressive gases. It is used in facility automation, in refrigeration, air conditioning, ventilation, and clean room technology, in greenhouses and in halls. It converts the measurands humidity and temperature into a standard signal of 0-10V or 4...20mA. Relative humidity (in % r.H.) is the quotient of water vapour partial pressure divided by the saturation vapour pressure at the respective gas temperature. These measuring transducers are designed for exact detection of temperature and humidity. A capacitive sensor is used as measuring element for measuring humidity. The enclosures are suitable for wall and duct installation.

TECHNICAL DATA:

Power supply: 24 V AC/DC for U variant
15...36V DC for I variant, $R_L < 500\Omega$

Sensors: capacitive humidity sensor with integrated temperature sensor,
dew-proof, small hysteresis, high long-term stability

Sensor protection: membrane filter, exchangeable

HUMIDITY:

Measuring range, humidity: 0...100% r.H.
(output corresponding to 0-10V or 4...20mA)

Operating range, humidity: 10...90% r.H.

Deviation, humidity: $\pm 3\%$ r.H. (40...60 %); at +20°C, otherwise $\pm 5\%$ r.H.

Output, humidity: 0-10V for U variant,
4...20mA for I variant (transmitter $R_L < 500\Omega$)

TEMPERATURE:

Measuring range, temperature:.. KFTF: 0...+50°C
AFTF: -20...+80°C
(output corresponding to 0-10V or 4...20mA)

Operating range, temperature:.. KFTF: 0...+50°C
AFTF: -20...+80°C

Deviation, temperature: $\pm 0.8\text{K}$ (KFF/KFTF-U), $\pm 0.8\text{K}$ (KFF/KFTF-I)
at 20°C, depending on place of installation and position

Output, temperature: 0-10V or 4...20mA or Ohm value

Ambient temperature:..... storage -25...+50°C, operation -5...+55°C

Electrical connection: 2-, 3-, or 4-wire connection (see connecting diagram),
0.14-1.5 mm² via terminal screws on circuit board

Enclosure: plastic, material polyamide, 30% glass-globe-reinforced,
with quick-locking screws,
colour pure white (similar RAL9010)

Dimensions: KFF/KFTF: 72 x 64 x 39.4 mm
AFF/AFTF: 108 x 70 x 73.5 mm

Cable union: M16, including strain relief

Protective tube: metal, $\varnothing 14\text{ mm}$,
KFF/KFTF: rated length NL = 230 mm
AFF/AFTF: rated length NL = 45 mm

Process connection: KFF/KFTF: by mounting flange, plastic,
(included in the scope of delivery),
(galvanised steel optional)
AFF/AFTF: by screws

Long-term stability:..... $\pm 1\%$ / per year

Protection class: III (according to EN 60730)

Protection type: IP 65 (according to IEC 529)

Standards: CE conformity, electromagnetic compatibility
according to EN 61326 + A1 + A2,
EMC directive 89/336/EWG
low-voltage directive 73/23/EWG

Optional: 8-digit display, cutout 36x14 mm (WxH),
for displaying actual Temperature and actual humidity



AFF/AFTF

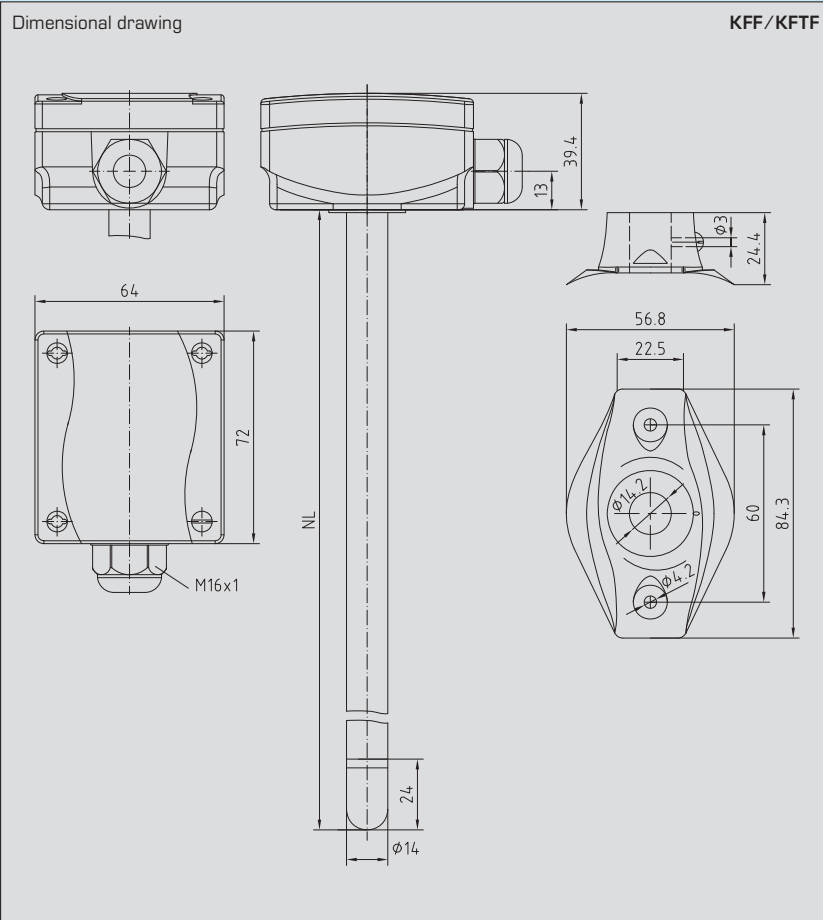

KFF/KFTF
with display

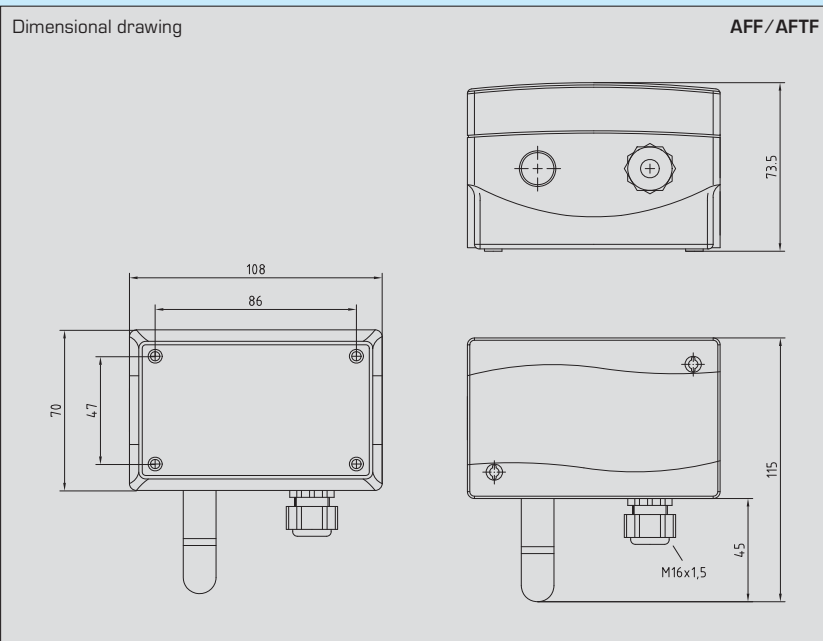

AFF/AFTF
with display



1

HYGRASGARD[®]

2

3

4

5

6

KFF/KFTF including mounting flange AFF/AFTF

Duct respectively on-wall humidity and temperature sensors
calibrateable, with active/passive output

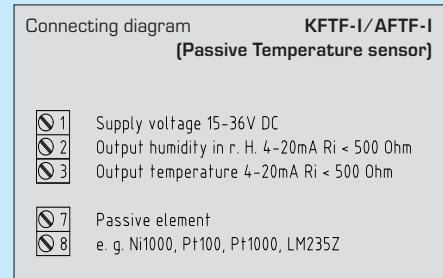
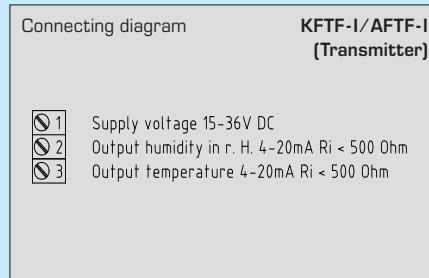
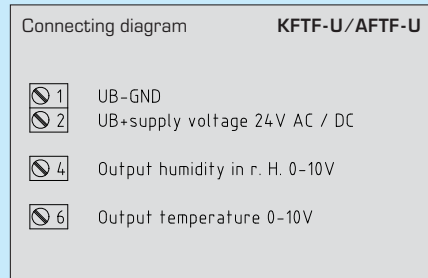
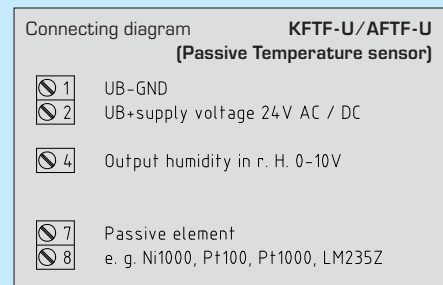
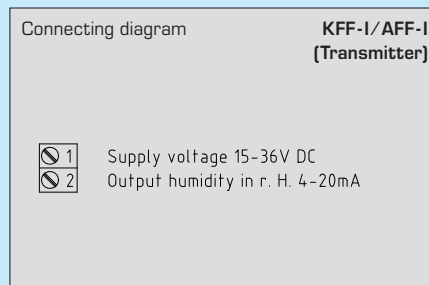
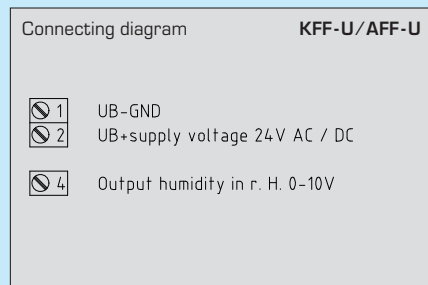
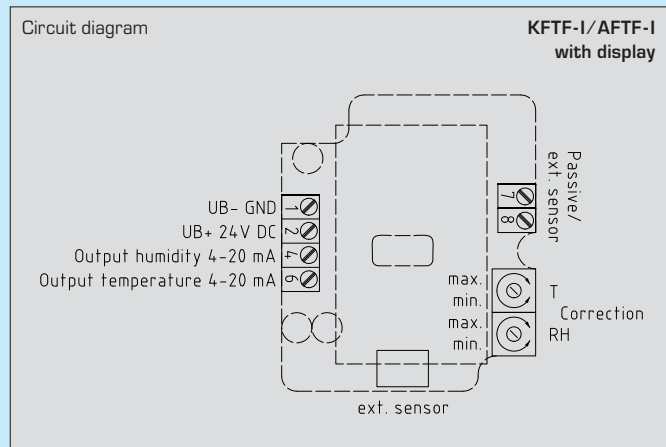
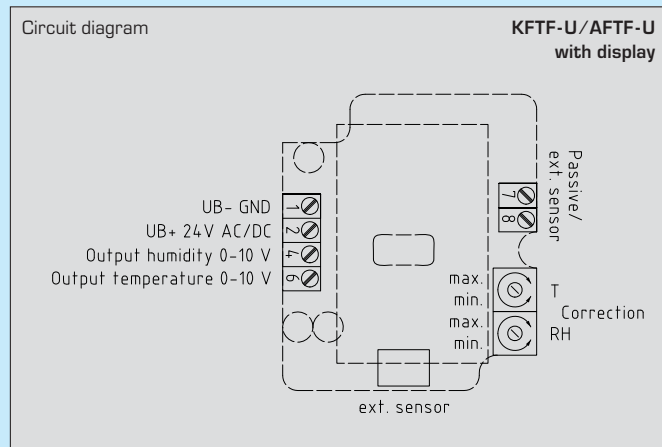

Duct humidity and temperature measuring transducers KFF and KFTF: Output: Temperature and humidity active, including mounting flange

Type/WG1	Range Humidity	Range Temperature	Output Humidity	Output Temperature
KFF-I	0...100% r.H.	-	4...20mA	-
KFF-U	0...100% r.H.	-	0-10V	-
KFTF-I	0...100% r.H.	0...50 °C	4...20mA	4...20mA
KFTF-U	0...100% r.H.	0...50 °C	0-10V	0-10V
KFF-/KFTF-xx-Display				

Duct humidity and temperature measuring transducer KFTF-U, x: Output: Humidity active, temperature passive, including mounting flange

Type/WG1	Range Humidity	Range Temperature	Output Humidity	Output Temperature
KFTF-U, Pt100	0...100% r.H.	-20...+80 °C	0-10 V	Pt100
KFTF-U, Pt1000	0...100% r.H.	-20...+80 °C	0-10 V	Pt1000
KFTF-U, Ni1000	0...100% r.H.	-20...+80 °C	0-10 V	Ni1000
KFTF-U, Ni1000TK5000	0...100% r.H.	-20...+80 °C	0-10 V	Ni1000 TK5000
KFTF-U, NTC 1,8 k	0...100% r.H.	-20...+80 °C	0-10 V	NTC 1.8k Ohm
KFTF-U, NTC 10 k	0...100% r.H.	-20...+80 °C	0-10 V	NTC 10k Ohm
KFTF-U, NTC 20 k	0...100% r.H.	-20...+80 °C	0-10 V	NTC 20k Ohm
KFTF-U, LM235Z	0...100% r.H.	-20...+80 °C	0-10 V	LM235Z, 10mV/K

Temperature table

Range: 0...+50°C

°C	Output voltage in V	Output current in mA
0	0	4.0
5	1	5.6
10	2	7.2
15	3	8.8
20	4	10.4
25	5	12.0
30	6	13.6
35	7	15.2
40	8	16.8
45	9	18.4
50	10	20.0

Temperature table

Range: -20...+80°C

°C	Output voltage in V	Output current in mA
-20	0	4.0
-15	0.5	4.8
-10	1.0	5.6
-5	1.5	6.4
0	2.0	7.2
5	2.5	8.0
10	3.0	8.8
15	3.5	9.6
20	4.0	10.4
25	4.5	11.2
30	5.0	12.0
35	5.5	12.8
40	6.0	13.6
45	6.5	14.4
50	7.0	15.2
55	7.5	16.0
60	8.0	16.8
65	8.5	17.6
70	9.0	18.4
75	9.5	19.2
80	10.0	20.0

Humidity table

Range: 0...100% r.H.

% r.H.	Output voltage in V	Output current in mA
0	0	4.0
5	0.5	4.8
10	1.0	5.6
15	1.5	6.4
20	2.0	7.2
25	2.5	8.0
30	3.0	8.8
35	3.5	9.6
40	4.0	10.4
45	4.5	11.2
50	5.0	12.0
55	5.5	12.8
60	6.0	13.6
65	6.5	14.4
70	7.0	15.2
75	7.5	16.0
80	8.0	16.8
85	8.5	17.6
90	9.0	18.4
95	9.5	19.2
100	10.0	20.0

On-wall humidity and temperature measuring transducer AFF and AFTFF:
Output: Humidity and temperature active

Type/WG1	Range Humidity	Range Temperature	Output Humidity	Output Temperature
AFF-I	0...100% r.H.	-	4...20mA	-
AFF-U	0...100% r.H.	-	0-10V	-
AFTF-I	0...100% r.H.	-20...+80°C	4...20mA	4...20mA
AFTF-U	0...100% r.H.	-20...+80°C	0-10V	0-10V
AFF-/AFTF-xx-Display				

On-wall humidity and temperature measuring transducer AFTF-U, x:
Output: Humidity active, temperature passive

Type/WG1	Range Humidity	Range Temperature	Output Humidity	Output Temperature
AFTF-U, Pt100	0...100% r.H.	-20...+80°C	0-10V	Pt100
AFTF-U, Pt1000	0...100% r.H.	-20...+80°C	0-10V	Pt1000
AFTF-U, Ni1000	0...100% r.H.	-20...+80°C	0-10V	Ni1000
AFTF-U, Ni1000TK5000	0...100% r.H.	-20...+80°C	0-10V	Ni1000 TK5000
AFTF-U, NTC 1,8 k	0...100% r.H.	-20...+80°C	0-10V	NTC 1.8k Ohm
AFTF-U, NTC 10 k	0...100% r.H.	-20...+80°C	0-10V	NTC 10k Ohm
AFTF-U, NTC 20 k	0...100% r.H.	-20...+80°C	0-10V	NTC 20k Ohm
AFTF-U, LM235Z	0...100% r.H.	-20...+80°C	0-10V	LM235Z, 10mV/K

KFF-20 / KFTF-20 including mounting flange AFF-20 / AFTF-20

Duct respectively on-wall humidity and temperature sensors
calibrateable, with active output



KFF-20 / KFTF-20



AFF-20 / AFTF-20

APPLICATION:

For advanced high-precision applications, accuracy 2 % r.H.

The calibrateable humidity/temperature sensor measures the relative humidity and temperature of air and other non-aggressive gases. It is used in meteorology, in medicine, in facility automation, in refrigeration, air conditioning, ventilation, and clean room technology, in greenhouses and in halls. It converts the measurands humidity and temperature into a standard signal of 0-10 V or 4...20 mA. Relative humidity (in % r.H.) is the quotient of water vapour partial pressure divided by the saturation vapour pressure at the respective gas temperature. These measuring transducers are designed for exact detection of temperature and humidity. A capacitive sensor is used as measuring element for measuring humidity. The enclosures are suitable for wall and duct installation.

TECHNICAL DATA:

- Power supply: 24 V AC/DC for U variant
15...36 V DC for I variant, $R_L < 500 \Omega$
- Sensors: capacitive humidity sensor with integrated temperature sensor,
dew-proof, small hysteresis, high long-term stability
- Sensor protection: membrane filter, exchangeable
- HUMIDITY:
- Measuring range, humidity: 0...100 % r.H.
(output corresponding to 0-10 V or 4...20 mA)
- Operating range, humidity: 10...90 % r.H.
- Deviation, humidity: $\pm 2\%$ r.H. (20...90 %); at +20 °C, otherwise $\pm 3\%$ r.H.
- Output, humidity: 0-10 V for U variant,
4...20 mA for I variant, (transmitter $R_L < 500 \Omega$)
- TEMPERATURE:
- Measuring range, temperature: ... -20...+80 °C
(output corresponding to 0-10 V or 4...20 mA or Ohm value)
- Operating range, temperature: ... -20...+80 °C
- Deviation, temperature: ± 0.3 K at 20 °C
- Output, temperature: 0-10 V or 4...20 mA
- Ambient temperature: storage -25...+50 °C, operation -5...+55 °C
- Electrical connection: 2-, 3-, or 4-Draht (see connecting diagram),
0.14-1.5 mm² via terminal screws on circuit board
- Enclosure: plastic, material polyamide, 30% glass-globe-reinforced,
with quick-locking screws,
colour pure white (similar RAL9010)
- Dimensions: KFF-20/KFTF-20: 72 x 64 x 39.4 mm
AFF-20/AFTF-20: 108 x 70 x 73.5 mm
- Cable union: M16, including strain relief
- Protective tube: metal, \varnothing 14 mm,
KFF-20/KFTF-20: rated length NL = 230 mm
AFF-20/AFTF-20: rated length NL = 45 mm
- Process connection: KFF-20/KFTF-20: by mounting flange, plastic,
(included in the scope of delivery), (galvanised steel optional)
AFF-20/AFTF-20: by screws
- Long-term stability: $\pm 1\%$ / per year
- Protection class: III (according to EN 60730)
- Protection type: IP 65 (according to IEC 529)
- Standards: CE conformity, electromagnetic compatibility
according to EN 61326 + A1 + A2,
EMC directive 89/336/EWG,
low-voltage directive 73/23/EWG
- Optional: 8-digit display, cutout 36 x 14 mm (W x H),
for displaying actual temperature and actual humidity

KFF-20/KFTF-20
 with display

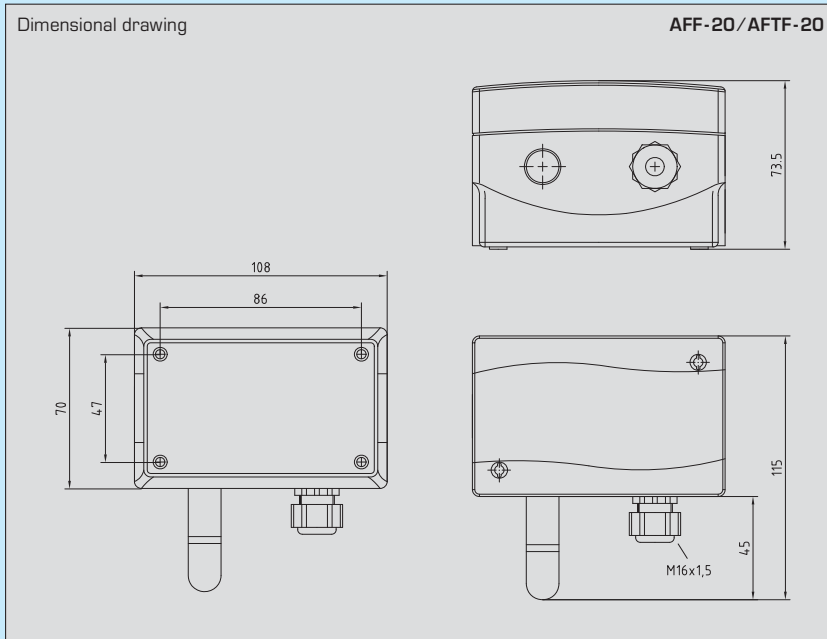
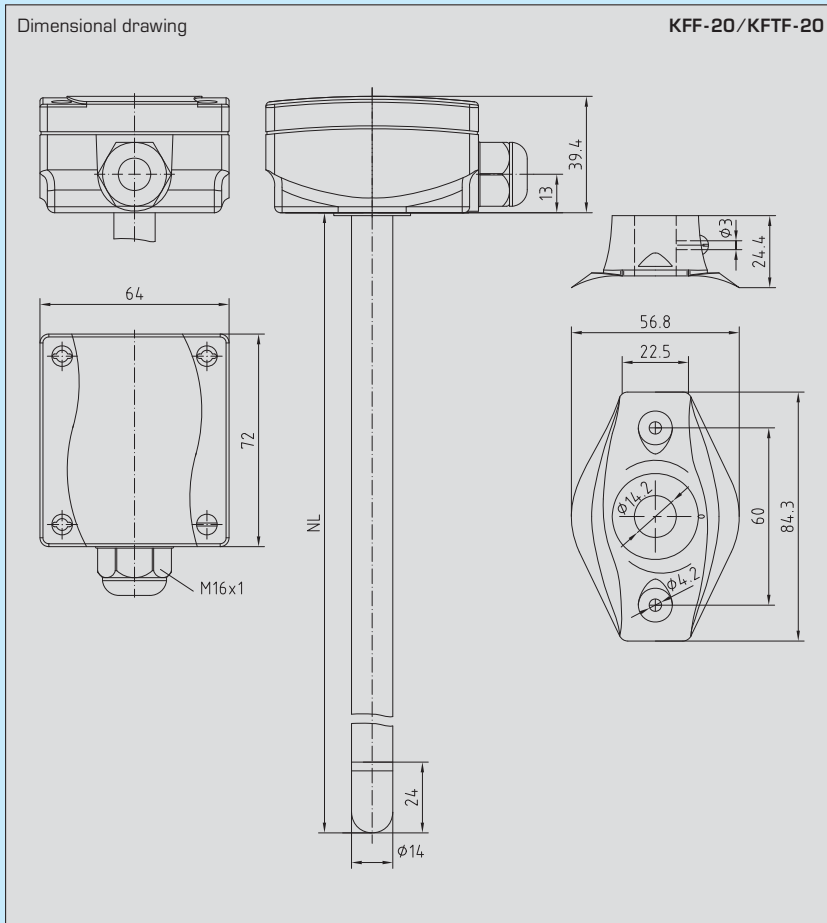

AFF-20/AFTF-20



AFF-20/AFTF-20
 with display

1

HYGRASGARD[®]

2

3

4

5

6

KFF-20 / KFTF-20 including mounting flange AFF-20 / AFTF-20

Duct respectively on-wall humidity and temperature sensors calibrateable, with active output

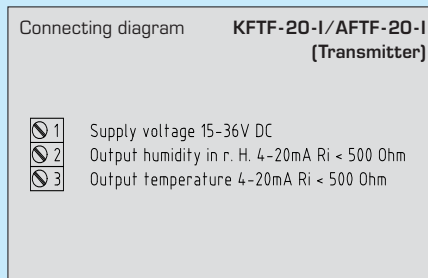
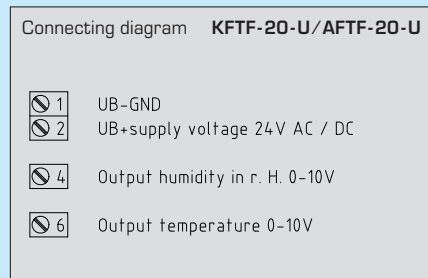
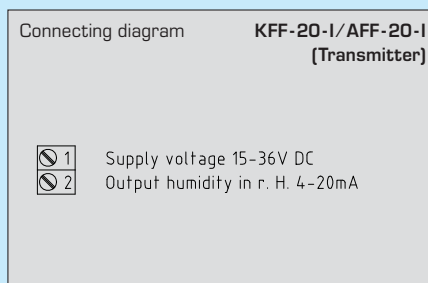
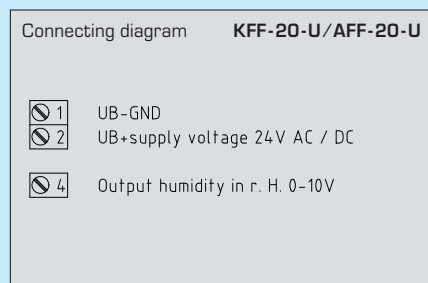
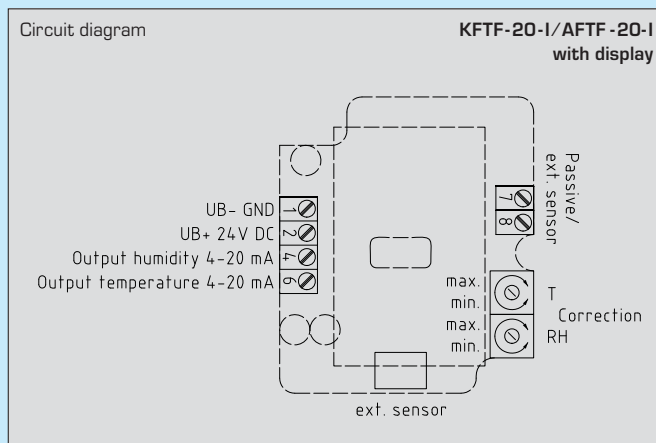
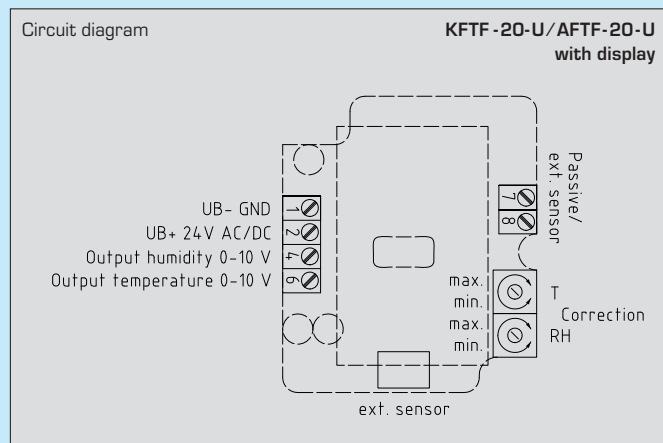

Duct humidity and temperature measuring transducers **KFF-20** and **KFTF-20**, including mounting flange :

Type/WG1	Range Humidity	Range Temperature	Output Humidity	Output Temperature
KFF-20 I	0...100% r.H.	-	4...20mA	-
KFF-20 U	0...100% r.H.	-	0-10 V	-
KFTF-20 I	0...100% r.H.	-20...+80 °C	4...20mA	4...20mA
KFTF-20 U	0...100% r.H.	-20...+80 °C	0-10 V	0-10 V
KFF-20 / KFTF-20-xx - Display				

Temperature table Range: -20...+80 °C

°C	Output voltage in V	Output current in mA
-20	0	4.0
-15	0.5	4.8
-10	1.0	5.6
-5	1.5	6.4
0	2.0	7.2
5	2.5	8.0
10	3.0	8.8
15	3.5	9.6
20	4.0	10.4
25	4.5	11.2
30	5.0	12.0
35	5.5	12.8
40	6.0	13.6
45	6.5	14.4
50	7.0	15.2
55	7.5	16.0
60	8.0	16.8
65	8.5	17.6
70	9.0	18.4
75	9.5	19.2
80	10.0	20.0

Temperature table showing temperature values in °C in relation to the respective output signal. Figures given in volt (V) and in milliampere (mA).

Humidity table: Range: 0...100 % r.H.

% r.H.	Output voltage in V	Output current in mA
0	0	4.0
5	0.5	4.8
10	1.0	5.6
15	1.5	6.4
20	2.0	7.2
25	2.5	8.0
30	3.0	8.8
35	3.5	9.6
40	4.0	10.4
45	4.5	11.2
50	5.0	12.0
55	5.5	12.8
60	6.0	13.6
65	6.5	14.4
70	7.0	15.2
75	7.5	16.0
80	8.0	16.8
85	8.5	17.6
90	9.0	18.4
95	9.5	19.2
100	10.0	20.0

Humidity table showing relative humidity values in percent [% r.H.] in relation to the respective output signal. Figures given in volt (V) and in milliampere (mA).

On-wall (outdoor) humidity and temperature measuring transducers AFF-20 and AFTF-20:

Type/WG1	Range Humidity	Range Temperature	Output Humidity	Output Temperature
AFF-20 I	0...100% r.H.	-	4...20mA	-
AFF-20 U	0...100% r.H.	-	0-10 V	-
AFTF-20 I	0...100% r.H.	-20...+80 °C	4...20mA	4...20mA
AFTF-20 U	0...100% r.H.	-20...+80 °C	0-10 V	0-10 V
AFF-20/AFTF-20-xx-Display				

KMVTF/KAFTF including mounting flange AMVTF/AAFTF

Duct respectively on-wall outdoor humidity sensors for proportion of mixture/absolute humidity and temperature



KMVTF/KAFTF

APPLICATION:

Series KMVTF and AMVTF humidity sensors are used for measuring temperature and determining the proportion of mixture (in g/kg) in ambient air. They convert these measurements into standard signals of 0-10V. Proportion of mixture g/kg, is the quotient mass of water vapour divided by mass of dry air. Series KAFTF and AAFTF humidity sensors are used for measuring temperature and absolute humidity (in g/m³) in ambient air. They convert these measurements into standard signals of 0-10V. Humidity sensors shall be operated in pollutant-free non-precipitating air. Applications in medical, refrigeration, air conditioning, and clean room technology for example. These sensors are suitable for wall and duct installation.

TECHNICAL DATA:

Power supply: 24V AC/DC
Sensors: capacitive humidity sensor with integrated temperature sensor, dew-proof, small hysteresis, high long-term stability ± 1% / per year
Sensor protection: membrane filter, exchangeable

HUMIDITY:

Measuring range, humidity: 0...100% r.H.
Operating range, humidity: 10...99% r.H.
Deviation, humidity: ± 3% r.H. (40...60%); at +20°C, otherwise ± 5% r.H.
Output proportion humidity: 0-10V for 0...80g/kg (AMVTF, KMVTF), values calculated from measured values
Output absolute humidity: 0-10V for 0...80g/m³ (AAFTF, KAFTF), values calculated from measured values

TEMPERATURE:

Measuring range, temperature: .. 0...+50°C (output corresponding to 0-10V)
Operating range, temperature: .. 0...+50°C
Deviation, temperature: ± 0.5K at 20°C
Output, temperature: 0-10V
Ambient temperature: storage -25...+60°C, operation -5...+55°C
Electrical connection: 4-wire connection (see connecting diagram), 0.14-1.5mm² via terminal screws on circuit board
Enclosure: plastic, material polyamide, 30% glass-globe-reinforced, with quick-locking screws, colour pure white (similar RAL9010)
Dimensions: KMVTF/KAFTF: 72x64x39.4mm
AMVTF/AAFTF: 108x70x73.5mm
Cable union: M16, including strain relief
Protective tube: metal, Ø 14mm, KMVTF/KAFTF: rated length NL=230mm
AMVTF/AAFTF: rated length NL=45mm
Process connection: KMVTF/KAFTF: by mounting flange, plastic, (included in the scope of delivery), (galvanised steel optional)
AMVTF/AAFTF: by screws
Protection class: III (according to EN 60730)
Protection type: IP 65 (according to IEC 529)
Standards: CE conformity, electromagnetic compatibility according to EN 61326+A1+A2, EMC directive 89/336/EWG low-voltage directive 73/23/EWG



AMVTF/AAFTF

Connecting diagram		KMVTF/AMVTF
1	UB-GND	
2	UB+supply voltage 24V AC / DC	
4	Output mixture ratio 0-10V	
6	Output temperature 0-10V	

Connecting diagram		KAFTF/AAFTF
1	UB-GND	
2	UB+supply voltage 24V AC / DC	
4	Output absolute humidity 0-10V	
6	Output temperature 0-10V	

Duct and on-wall outdoor humidity sensor for proportion of mixture KMVTF, AMVTF:

Type/WG1	Range Humidity	Range Temperature	Output Humidity	Output Temperature
AMVTF-U	0...80g/kg	0...+50°C	0-10V	0-10V
KMVTF-U	0...80g/kg	0...+50°C	0-10V	0-10V
AMVTF/KMVTF-U-Display				

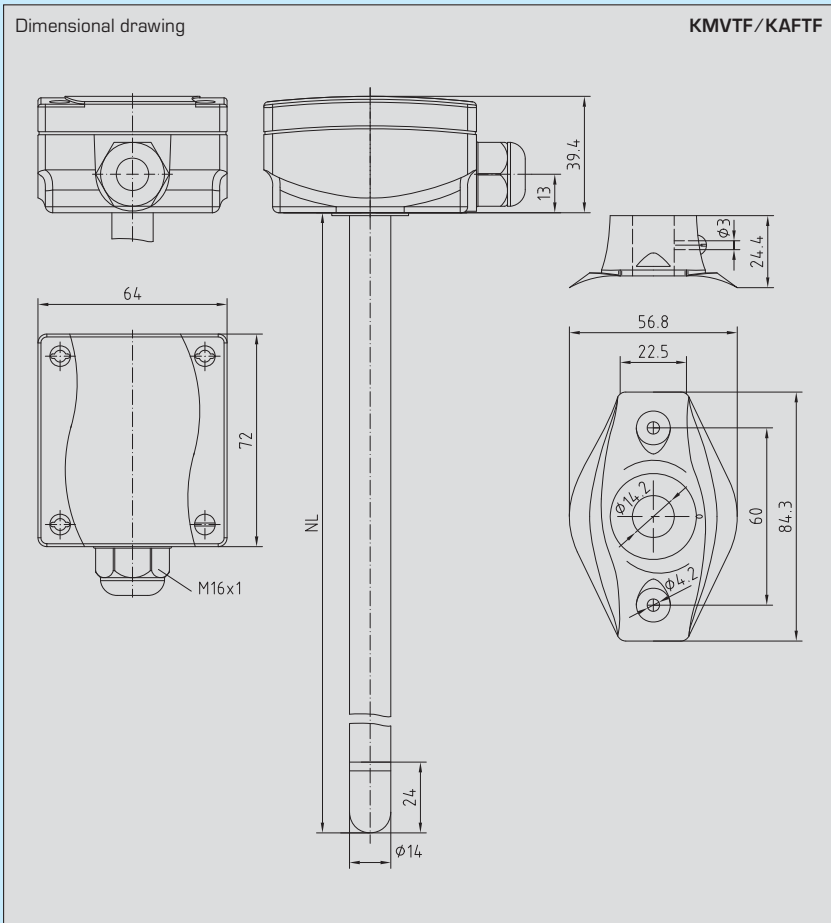

KMVTF/KAFTF
with display

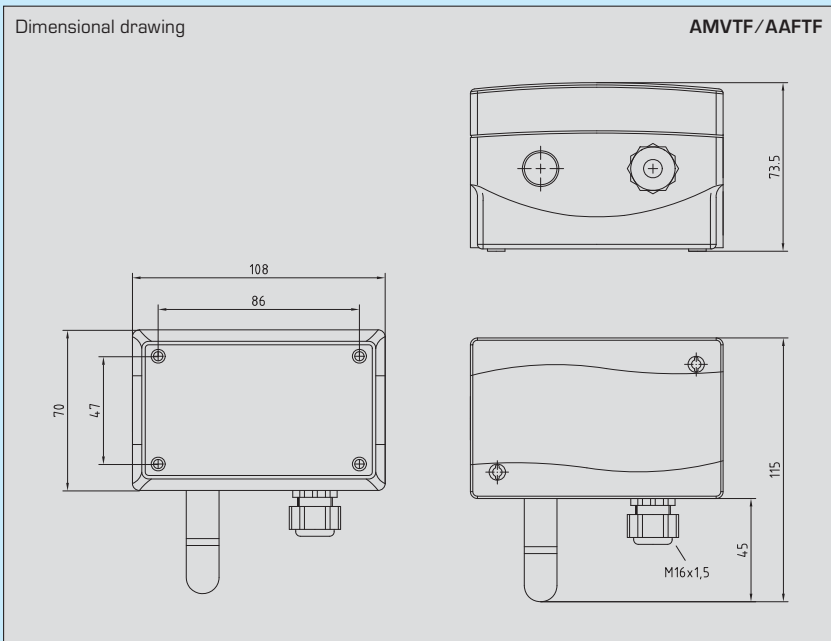

AMVTF/AAFTF
with display



Duct and on-wall outdoor humidity sensor for absolute humidity KAFTF, AAFTF:

Type/WG1	Range Humidity	Range Temperature	Output Humidity	Output Temperature
AAFTF-U	0...80g/kg	0...+50°C	0-10V	0-10V
KAFTF-U	0...80g/kg	0...+50°C	0-10V	0-10V
AAFTF/KAFTF-U-Display				

Room humidity and temperature sensors, on-wall, calibrateable, with active/passive output, series Odin I

RFF/RFTF

APPLICATION:

For HVAC sector, accuracy 3 % R. H.

The calibrateable humidity/temperature sensor measures the relative humidity and temperature of air and other non-aggressive gases. It is used in refrigeration, air conditioning, and clean room technology, in residential rooms, offices, hotels, technical rooms, meeting rooms and convention centres.

It converts the measurands humidity and temperature into a standard signal of 0-10V or 4...20mA. Relative humidity (in % r.H.) is the quotient of water vapour partial pressure divided by the saturation vapour pressure at the respective gas temperature. These measuring transducers are designed for exact detection of temperature and humidity. A capacitive sensor is used as measuring element for measuring humidity.



TECHNICAL DATA:

- Power supply: 24 V AC/DC for U variant
15...36 V DC for I variant, $R_L < 500 \Omega$
- Sensors: capacitive humidity sensor with integrated temperature sensor, dew-proof, small hysteresis, high long-term stability
- HUMIDITY:**
- Measuring range, humidity: 0...100% r.H.
(output corresponding to 0-10 V or 4...20 mA)
- Operating range, humidity: 10...90% r.H.
- Deviation, humidity: $\pm 3\%$ r.H. (40...60%); at +20 °C, otherwise $\pm 5\%$ r.H.
- Output, humidity: 0-10 V for U variant,
4...20 mA for I variant, (transmitter, $R_L < 500 \Omega$)
- TEMPERATURE:**
- Measuring range, temperature: .. 0...+50 °C
(output corresponding to -10V or 4...20 mA or Ohm value)
- Operating range, temperature: .. 0...+50 °C
- Deviation, temperature: $\pm 0.8\text{K}$ (RFF/RFTF-U), $\pm 0.8\text{K}$ (RFF/RFTF-I)
at 20 °C under standard conditions
- Output, temperature: 0-10V or 4...20 mA or Ohm value
- Ambient temperature: storage -25...+50 °C, operation -5...+55 °C
- Electrical connection: 2-, 3-, or 4-wire connection (see connecting diagram),
0.14-1.5 mm² via terminal screws on circuit board
- Enclosure: plastic, material ABS,
colour pure white (similar RAL9010),
stainless steel enclosure optional
- Dimensions: 79 x 81 x 26 mm
- Installation: wall mounting or on in-wall flush box $\varnothing 55$ mm,
base with 4 holes for mounting on vertically or
horizontally installed flush boxes, with predetermined
breaking point for on-wall cable entry
- Long-term stability: $\pm 1\%$ / per year
- Protection class: III (according to EN 60730)
- Protection type: IP30 (according to IEC 529)
- Standards: CE conformity, electromagnetic compatibility
according to EN 61326 + A1 + A2,
EMC directive 89/336/EWG
low-voltage directive 73/23/EWG
- Optional: 8-digit display, cutout 36x14 mm (WxH),
for displaying actual temperature and/or actual humidity
- ZUBEHÖR: see last chapter

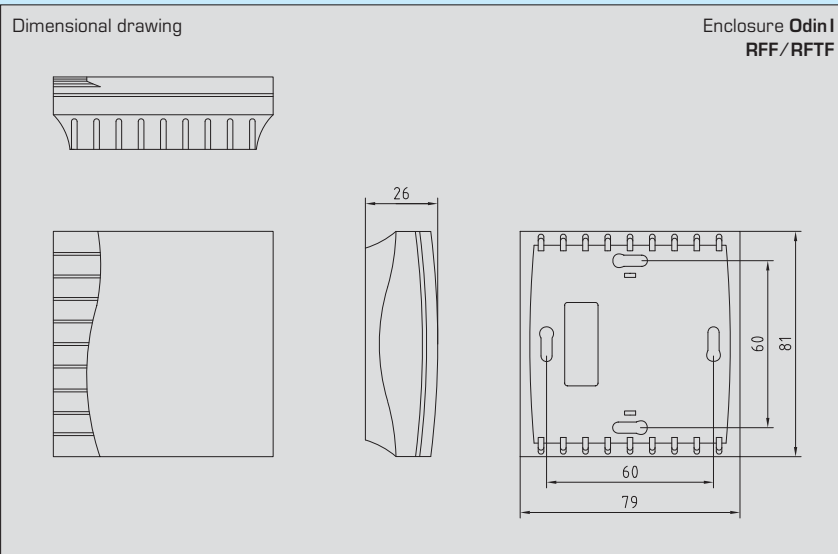

RFF/RFTF
with display

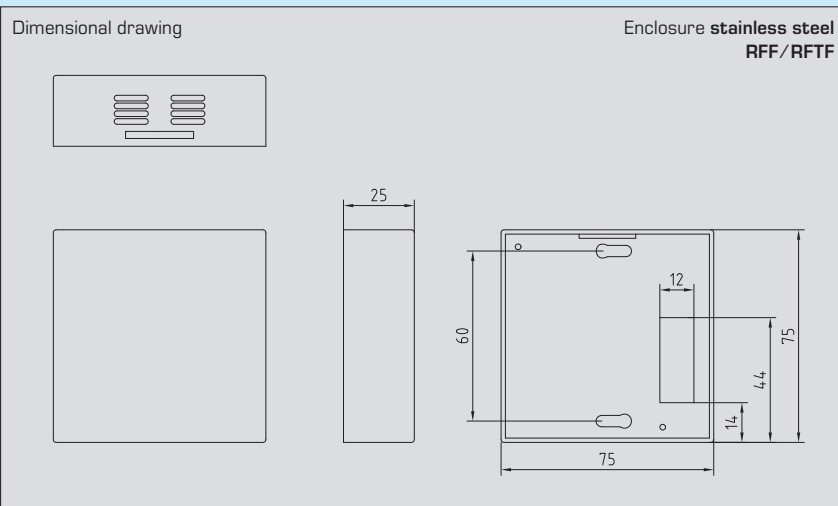

RFF/RFTF
with stainless steel
enclosure



1

HYGRASCARD[®]

2

3

4

5

6

RFF/RFTF

Room humidity and temperature sensors, on-wall, calibrateable, with active/passive output, series Odin I



1

Connecting diagram RFF-U

- 1 UB-GND
- 2 UB+supply voltage 24V AC / DC
- 4 Output humidity in r. H. 0-10V

Connecting diagram RFF-I (Transmitter)

- 1 Supply voltage 15-36V DC
- 2 Output humidity in r. H. 4-20mA

Connecting diagram RFTF-U (Passive temperature sensor)

- 1 UB-GND
- 2 UB+supply voltage 24V AC / DC
- 4 Output humidity in r. H. 0-10V
- 7 Passive element
- 8 e. g. Ni1000, Pt100, Pt1000, LM235Z

HYGRASGARD®

Connecting diagram RFTF-U RFTF-U with display

- 1 UB-GND
- 2 UB+supply voltage 24V DC
- 4 Output humidity in r. H. 0-10V
- 6 Output temperature 0-10V

Connecting diagram RFTF-I (Transmitter)

- 1 Supply voltage 15-36V DC
- 2 Output humidity in r. H. 4-20mA Ri < 500 Ohm
- 3 Output temperature 4-20mA Ri < 500 Ohm

Connecting diagram RFTF-I (Passive temperature sensor)

- 1 Supply voltage 15-36V DC
- 2 Output humidity in r. H. 4-20mA Ri < 500 Ohm
- 7 Passive element
- 8 Ni 1000, Pt 100, Pt1000, LM235Z

3

Connecting diagram RFTF-I with display

- 1 UB-GND
- 2 UB+supply voltage 24V DC
- 4 Output humidity in r. H. 4-20mA
- 6 Output temperature 4-20mA

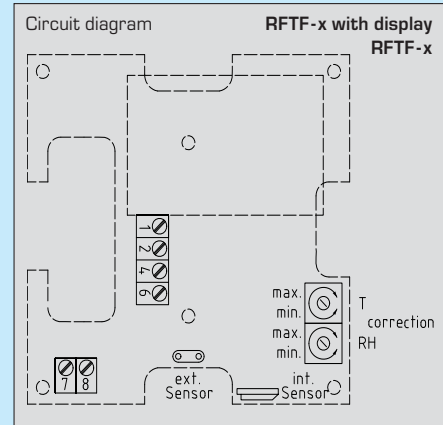
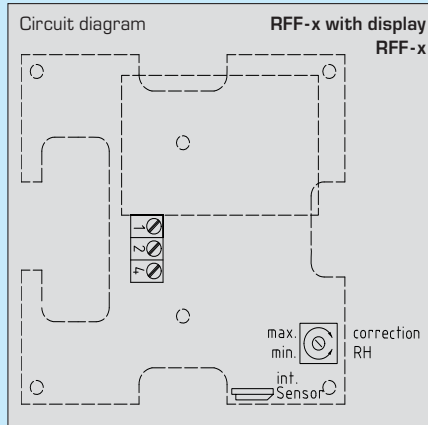

4

Room humidity and temperature measuring transducer RFTF-U, x:
Output: Humidity active, temperature passive

Type/WG1	Range Humidity	Range Temperature	Output Humidity	Output Temperature
RFTF-U, Pt100	0...100% r.H.	0...50 °C	0-10V	Pt100
RFTF-U, Pt1000	0...100% r.H.	0...50 °C	0-10V	PT1000
RFTF-U, Ni1000	0...100% r.H.	0...50 °C	0-10V	Ni1000
RFTF-U, Ni1000TK5000	0...100% r.H.	0...50 °C	0-10V	Ni1000TK5000
RFTF-U, NTC 1,8 k	0...100% r.H.	0...50 °C	0-10V	NTC 1.8k Ohm
RFTF-U, NTC 10 k	0...100% r.H.	0...50 °C	0-10V	NTC 10k Ohm
RFTF-U, NTC 20 k	0...100% r.H.	0...50 °C	0-10V	NTC 20k Ohm
RFTF-U, LM235Z	0...100% r.H.	0...50 °C	0-10V	LM235Z, 10mV/K

6

Humidity table

Range: 0...100% r.H.

% r.H.	Output voltage in V	Output current in mA
0	0	4.0
5	0.5	4.8
10	1.0	5.6
15	1.5	6.4
20	2.0	7.2
25	2.5	8.0
30	3.0	8.8
35	3.5	9.6
40	4.0	10.4
45	4.5	11.2
(continuation see next column)		

% r.H.	Output voltage in V	Output current in mA
50	5.0	12.0
55	5.5	12.8
60	6.0	13.6
65	6.5	14.4
70	7.0	15.2
75	7.5	16.0
80	8.0	16.8
85	8.5	17.6
90	9.0	18.4
95	9.5	19.2
100	10.0	20.0

Temperature table

Range: 0...+50°C

°C	Output voltage in V	Output current in mA
0	0	4.0
5	1	5.6
10	2	7.2
15	3	8.8
20	4	10.4
25	5	12.0
30	6	13.6
35	7	15.2
40	8	16.8
45	9	18.4
50	10	20.0

Room humidity and temperature measuring transducers RFF and RFTF:

Output: Temperature and humidity active

Type/WG1	Range Humidity	Range Temperature	Output Humidity	Output Temperature
RFF-I	0...100% r.H.	-	4...20mA	-
RFF-U	0...100% r.H.	-	0-10V	-
RFTF-I	0...100% r.H.	0...50°C	4...20mA	4...20mA
RFTF-U	0...100% r.H.	0...50°C	0-10V	0-10V
RFTF- stainless steel enclosure				

Room humidity and temperature measuring transducers RFF and RFTF with display:

Output: Temperature and humidity active

Type/WG1	Range/display Humidity	Range/display Temperature	Output Humidity	Output Temperature
RFF-I-Display	0...100% r.H.	-	4...20mA	-
RFF-U-Display	0...100% r.H.	-	0-10V	-
RFTF-I-Display	0...100% r.H.	0...50°C	4...20mA	4...20mA
RFTF-U-Display	0...100% r.H.	0...50°C	0-10V	0-10V

RFF-UP/RFTF-UP

Room humidity and temperature sensors
in-wall, panel switch programme,
with active output



RFF-UP/RFTF-UP

APPLICATION:

For HVAC sector, accuracy 3 % R. H.

The humidity/temperature sensor measures the relative humidity and temperature of air and other non-aggressive gases. It is used in refrigeration, air conditioning, and clean room technology, in residential rooms, offices, hotels, technical rooms, meeting rooms and convention centres. It converts the measurands humidity and temperature into a standard signal of 0-10V or 4...20mA.

Relative humidity (in % r.H.) is the quotient of water vapour partial pressure divided by the saturation vapour pressure at the respective gas temperature. These measuring transducers are designed for exact detection of temperature and humidity. A capacitive sensor is used as measuring element for measuring humidity.

TECHNICAL DATA:

Power supply: 24V AC/DC
Sensors: capacitive humidity sensor with integrated temperature sensor, dew-proof, small hysteresis, high long-term stability

HUMIDITY:

Measuring range, humidity: 0...100% r.H.
(output corresponding to 0-10V)

Operating range, humidity: 10...90% r.H.

Deviation, humidity: $\pm 5\%$ r.H. at +20 °C

Output, humidity: 0-10V

TEMPERATURE:

Measuring range, temperature: .. 0...+50 °C
(output corresponding to 0-10V or 4...20mA)

Operating range, temperature: .. 0...+50 °C

Deviation, temperature: ± 1 K, depending on place of installation and position, sometimes also more

Output, temperature: 0-10V

Ambient temperature:..... storage -25...+50 °C, operation -5...+50 °C

Electrical connection: 2-, 3-, or 4-wire connection (see connecting diagram),
0.14 - 1.5 mm² via plug terminals

Installation:..... in in-wall flush box \varnothing 55mm

Long-term stability:..... $\pm 1\%$ /per year

Protection class:..... III (according to EN 60730)

Protection type: IP 20 (according to IEC 529)

Standards: CE conformity, electromagnetic compatibility
according to EN 61326 + A1 + A2,
EMC directive 89/336/EWG,
low-voltage directive 73/23/EWG

SWITCH PROGRAMME:

Manufacturer:..... Busch-Jaeger Reflex Si
(other switch programmes, manufacturers,
colours and prices upon request)

Enclosure:..... plastic, standard colour alpine white (similar RAL9010)
(other colours are possible upon request with colour variants-
depending on the respective light switch programme)

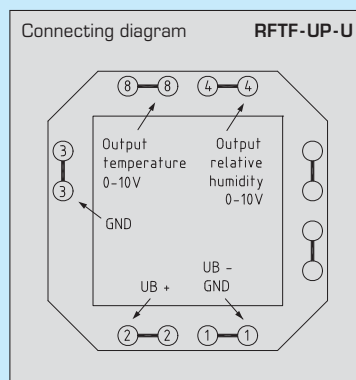
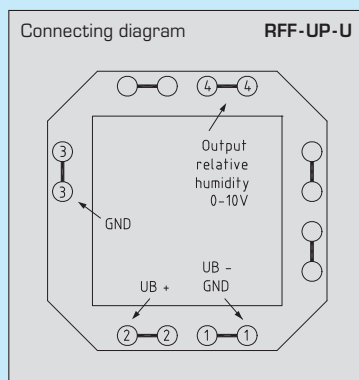

In case of output 0-10V,
GND connections (1), (3), and (7)
are connected on the circuit board.

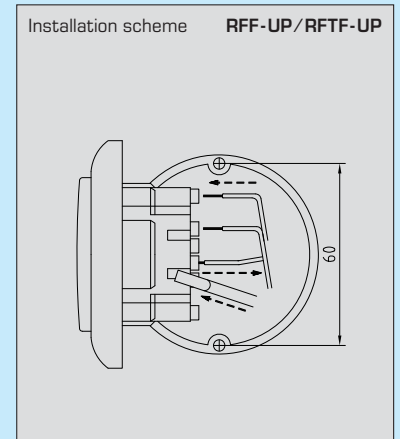
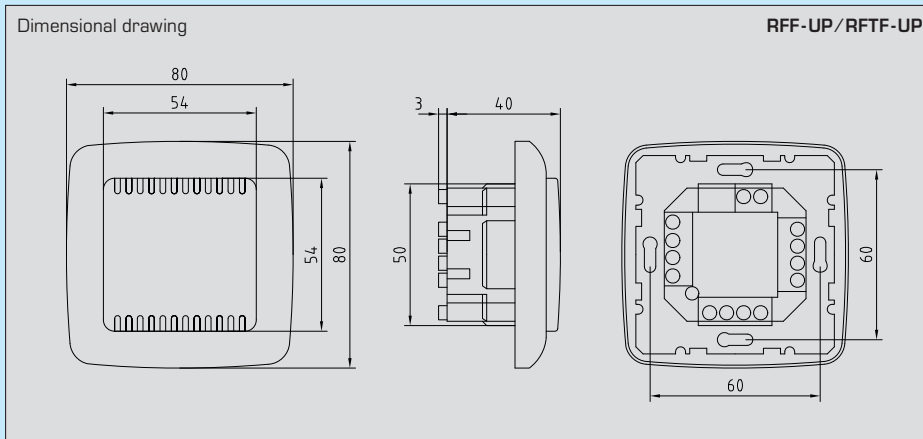

Humidity table

Range: 0...100% r.H.

% r.H.	Output voltage in V	Output current in mA
0	0	4.0
5	0.5	4.8
10	1.0	5.6
15	1.5	6.4
20	2.0	7.2
25	2.5	8.0
30	3.0	8.8
35	3.5	9.6
40	4.0	10.4
45	4.5	11.2
50	5.0	12.0
55	5.5	12.8
60	6.0	13.6
65	6.5	14.4
70	7.0	15.2
75	7.5	16.0
80	8.0	16.8
85	8.5	17.6
90	9.0	18.4
95	9.5	19.2
100	10.0	20.0

Temperature table

Range: 0...+50°C

°C	Output voltage in V	Output current in mA
0	0	4.0
5	1	5.6
10	2	7.2
15	3	8.8
20	4	10.4
25	5	12.0
30	6	13.6
35	7	15.2
40	8	16.8
45	9	18.4
50	10	20.0

Room humidity and temperature measuring transducers RFF-UP and RFTF-UP for in-wall installation:

Type/WG1	Range Humidity	Range Temperature	Output Humidity	Output Temperature
RFF-UP-U	0...100% r.H.	-	0-10V	-
RFTF-UP-U	0...100% r.H.	0...50°C	0-10V	0-10V

Pendulum room humidity and temperature sensors calibrateable, with active output

APPLICATION:

For HVAC sector, accuracy 3 % R. H.

The calibrateable humidity/temperature sensor measures the relative humidity and temperature of air and other non-aggressive gases. It is used in facility automation, in refrigeration, air conditioning, ventilation, and clean room technology, in greenhouses and in halls. It converts the measurands humidity and temperature into a standard signal of 0-10V or 4...20mA. Relative humidity (in % r.H.) is the quotient of water vapour partial pressure divided by the saturation vapour pressure at the respective gas temperature. These measuring transducers are designed for exact detection of temperature and humidity. A capacitive sensor is used as measuring element for measuring humidity. This sensor is suitable for ceiling or duct installation or for integrating it in devices.

TECHNICAL DATA:

- Power supply: 24V AC/DC for U variant
15...36V DC for I variant, $R_L < 500 \Omega$
- Sensors: capacitive humidity sensor with integrated temperature sensor, dew-proof, small hysteresis, high long-term stability
- Sensor protection: membrane filter, exchangeable
- HUMIDITY:
- Measuring range, humidity: 0...100% r.H.
(output corresponding to 0-10V or 4...20mA)
- Operating range, humidity: 10...100% r.H.
- Deviation, humidity: $\pm 3\%$ r.H. (20...90%); at +20 °C, otherwise $\pm 5\%$ r.H.
- Output, humidity: 0-10V for U variant,
4...20mA for I variant, (transmitter $R_L < 500 \Omega$)
- TEMPERATURE:
- Measuring range, temperature: .. 0...+50 °C
(output corresponding to 0-10V or 4...20mA)
- Operating range, temperature: .. 0...+50 °C
- Deviation, temperature: $\pm 0.3K$ (RPFF/RPFTF-U), $\pm 0.5K$ (RPFF/RPFTF-I) at 20 °C
- Output, temperature: 0-10V or 4...20mA
- Ambient temperature: storage -25...+50 °C, operation -5...+55 °C
- Long-term stability: $\pm 1\%$ /per year
- Electrical connection: 2-, 3-, or 4-wire connection (see connecting diagram),
0.14 - 1.5 mm² via terminal screws on circuit board
- Cable length: 2 m, other lengths optional
- Enclosure: plastic, material polyamide, 30 % glass-globe-reinforced,
with quick-locking screws,
colour pure white (similar RAL9010)
- Dimensions: 72 x 64 x 39.4 mm
- Cable union: M16, including strain relief
- Protective tube: metal, L=100 mm + 25 mm, $\varnothing=14$ mm
- Protection class: III (according to EN 60730)
- Protection type: IP 65 (according to IEC 529)
- Standards: CE conformity, electromagnetic compatibility
according to EN 61 326 + A1 + A2,
EMC directive 89/336/EWG
low-voltage directive 73/23/EWG
- Optional: 8-digit display, cutout 36x14 mm (WxH),
for displaying actual temperature and actual humidity



RPFF/RPFTF

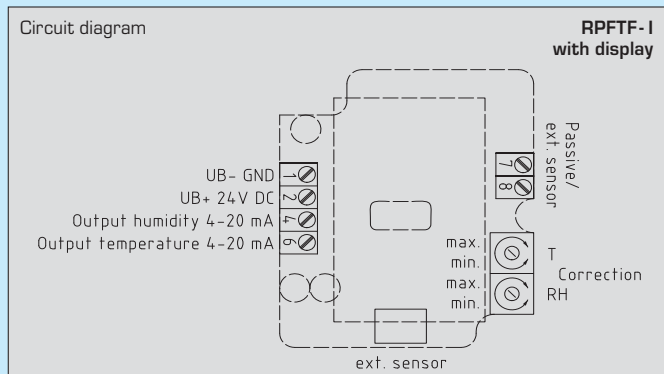
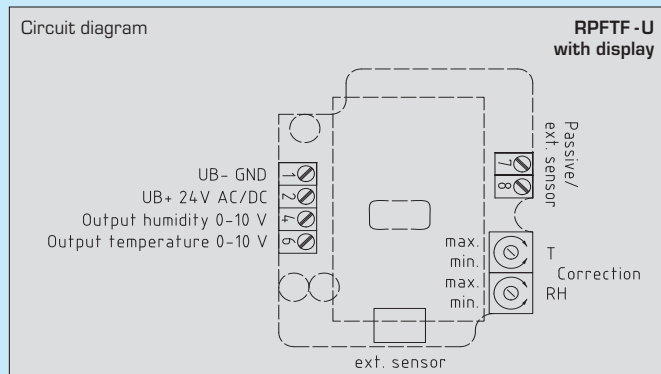
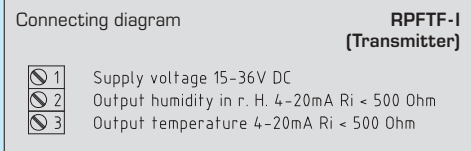
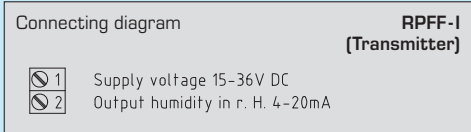
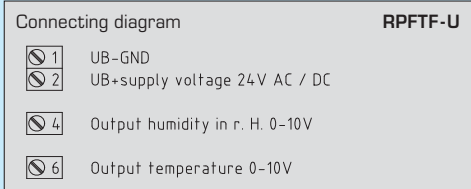
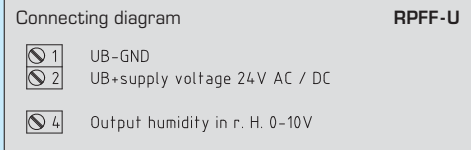

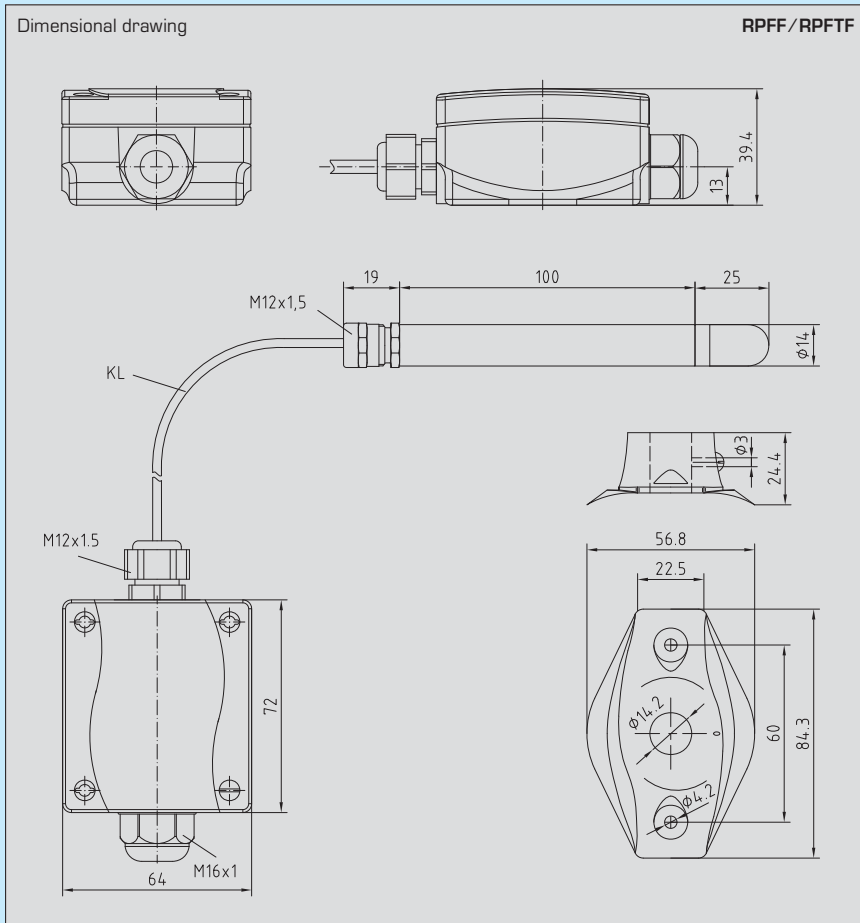

Humidity table Range: 0...100% r.H.

% r.H.	Output voltage in V	Output current in mA
0	0	4.0
5	0.5	4.8
10	1.0	5.6
15	1.5	6.4
20	2.0	7.2
25	2.5	8.0
30	3.0	8.8
35	3.5	9.6
40	4.0	10.4
45	4.5	11.2
(continuation see next column) ...		

% r.H.	Output voltage in V	Output current in mA
50	5.0	12.0
55	5.5	12.8
60	6.0	13.6
65	6.5	14.4
70	7.0	15.2
75	7.5	16.0
80	8.0	16.8
85	8.5	17.6
90	9.0	18.4
95	9.5	19.2
100	10.0	20.0

Temperature table Range: 0...+50°C

°C	Output voltage in V	Output current in mA
0	0	4.0
5	1	5.6
10	2	7.2
15	3	8.8
20	4	10.4
25	5	12.0
30	6	13.6
35	7	15.2
40	8	16.8
45	9	18.4
50	10	20.0

Room humidity and temperature measuring transducers RPFF and RPFTF:

Type/WG1	Range Humidity	Range Temperature	Output Humidity	Output Temperature
RPFF-I	0...100% r.H.	-	4...20mA	-
RPFF-U	0...100% r.H.	-	0-10 V	-
RPFTF-I	0...100% r.H.	0...50°C	4...20mA	4...20mA
RPFTF-U	0...100% r.H.	0...50°C	0-10 V	0-10 V
RPFF / RPFTF-xx-Display				
Accessories:	MF-14-K Mounting flange, plastic			

TW including strap



Dew point control switch with active/switching output

TW

APPLICATION:

The moisture sensor TW is installed on cooling or coldwater piping or on cooled surfaces. It can be used as moisture sensor, dew point control switch or limit switch on pipes. Dew point temperature is that temperature, at which air reaches the condition of saturation and water starts to precipitate. With limit values being adjustable between 80...100%, cooling ceilings or pipes for example or other objects to be monitored can be operated while avoiding the generation of dew by activating the switching output of the dew point control switch and thus, initiating a heating system or other actuators. Moisture is detected by a capacitive humidity sensor.

TECHNICAL DATA:

- Power supply: 24 V AC/DC
- Measuring range: 0 ...100% r.H., TW-U, continuous
80 ...100% TW-S, TW-Ö, adjustable,
generation of dew is detected,
shifting value can be adjusted at a potentiometer
- Internal current consumption: .. 5 mA, with relay max. 20 mA
- Output signal: 0-10V or potential-free normally-open/breaker contact,
function normally-open/breaker selectable by jumper
- Process connection: endless metal strap with metal tightener,
length = 300mm for pipes up to 3" diameter
(included in the scope of delivery)
- Electrical connection: 0.14 - 1.5 mm² via terminal screws
- Enclosure: plastic, material polyamide,
30% glass-globe-reinforced,
with quick-locking screws,
colour pure white (similar RAL9010)
- Dimensions: 72 x 64 x 39.4 mm
- Cable union: M16, including strain relief
- Protection class: III (according to EN 60730)
- Protection type: IP 65 (according to IEC 529)
- Standards: CE conformity,
electromagnetic compatibility
according to EN 61326 + A1 + A2,
EMC directive 89/336/EWG
low-voltage directive 73/23/EWG

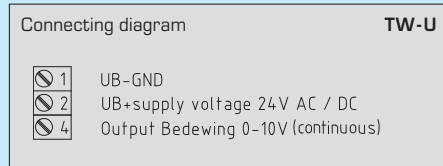
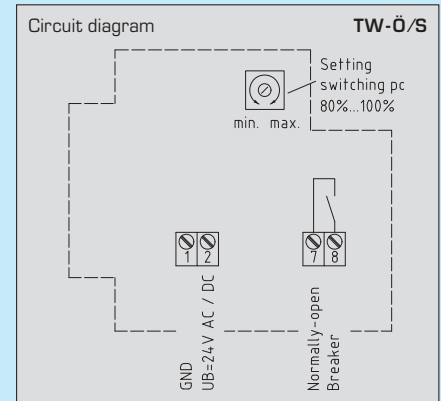
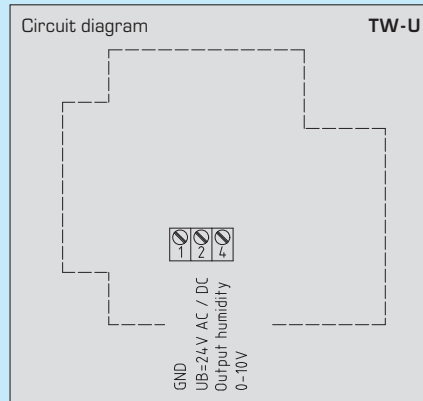
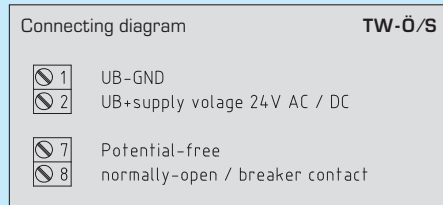
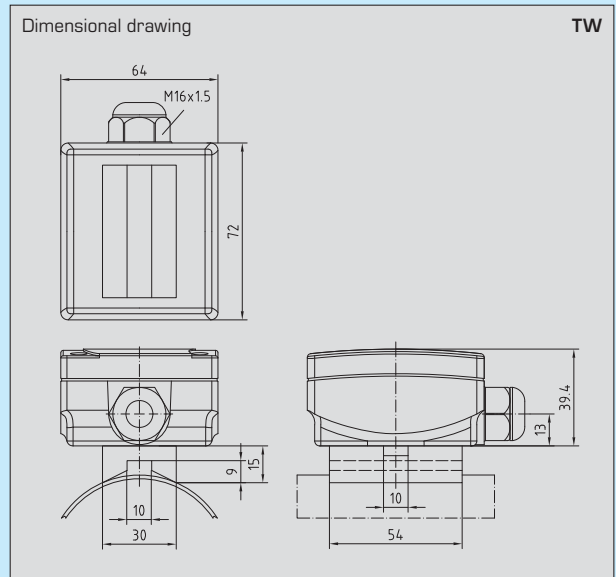

Dew point control switch TW, including strap:

Type/WG1	Range Humidity	Output Humidity
TW-U	0 ...100% r.H.	0-10V
TW-Ö/S	80 ...100% r.H.	Breaker/normally-open contact

KW including strap

Condensation control switch with switching output

APPLICATION:

The condensation control switch is installed on cooling or coldwater piping or on cooled surfaces to detect generation of dew. Monitoring cooling ceilings or pipes, it can be operated so that the switching output is activated when dew is generating on cooling ceilings or the object to be monitored, thus starting a heating system or other actuators.

TECHNICAL DATA:

- Power supply: 24 V AC/DC
- Monitoring range: ca. 95 % r.H.
- Switching threshold: ca. 95 % r.H.,
variation of ca. ±5% r.H. possible by potentiometer
- Internal current consumption: .. max. 20 mA
- Output signal: potential-free normally-open/breaker contact,
function normally-open/breaker selectable by jumper
- Process connection: endless metal strap with metal tightener,
length = 300 mm for pipes up to 3" diameter
(included in the scope of delivery)
- Electrical connection: 0.14 - 1.5 mm² via terminal screws
- Enclosure: plastic, material polyamide,
30% glass-globe-reinforced,
with quick-locking screws,
colour pure white [similar RAL9010]
- Dimensions: 72 x 64 x 39.4 mm
- Cable union: M16, including strain relief
- Protection class: III (according to EN 60730)
- Protection type: IP 65 (according to IEC 529)
- Standards: CE conformity,
electromagnetic compatibility
according to EN 61326 + A1 + A2,
EMC directive 89/336/EWG,
low-voltage directive 73/23/EWG

KW

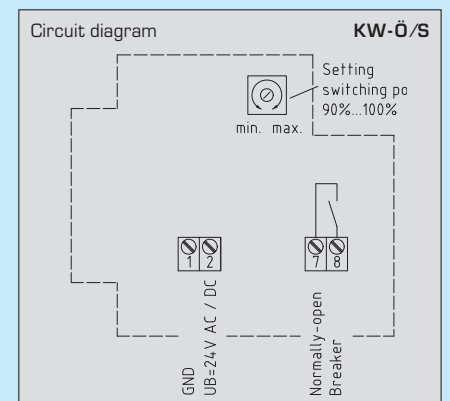
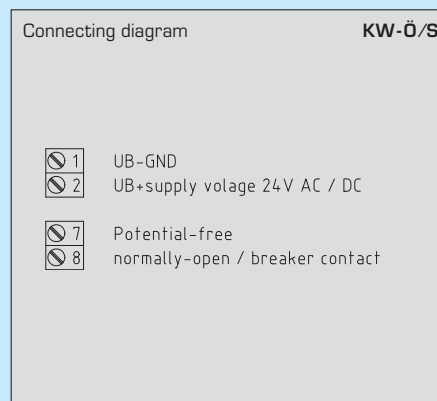
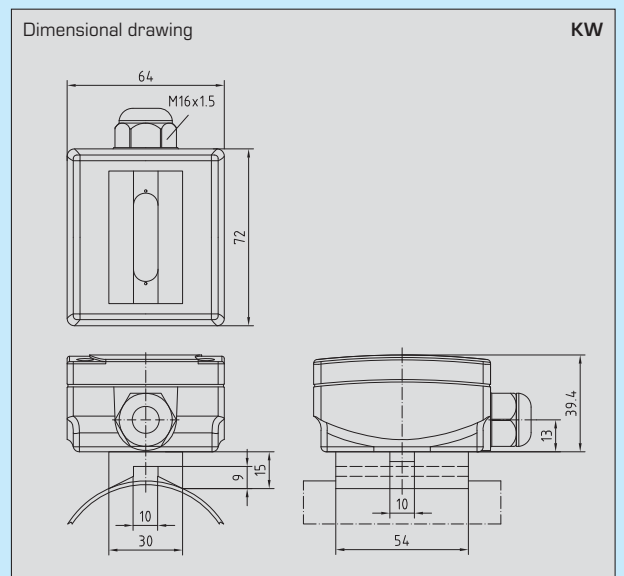

Condensation control switch KW, including strap:

Type/WG1	Range Humidity	Output Humidity
KW-Ö/S	ca. 95 % r.H.	Breaker/normally-open contact

Room hygro-thermostat mechanical

APPLICATION:

For controlling and monitoring temperature and relative humidity (humidifying and dehumidifying) in office and residential rooms, baths, winter gardens, labs, computer rooms, etc. Not applicable for aggressive gases.

RHT

TECHNICAL DATA:

HYGROSTAT

Power supply: 24...230 V AC
>24V in dry rooms only
according to VDE 0110

Setting range: 35...100% r.H.

Switching capacity: dehumidifying 5 (0.2) A, min. 100mA
(Contact load)
humidifying 3 (0.2) A, min. 100mA

Contact: 1 changeover contact, (potential-free)

Sensor element: plastic fibres

Tolerance:..... max. 3% r.H.

Operating difference: ca. 4% r.H.

Enclosure temperature:..... 0°C...+60°C



FUNCTION:

Humidifying: wire terminals 5 and 6
Dehumidifying: wire terminals 5 and 7

THERMOSTAT

Switching capacity: 10 (4)A, 24/230V AC

Control range: +10°C...+35°C

Contact: 1 changeover contact, (potential-free)

Sensor element: bimetal
with thermal feedback

FUNCTION:

Heating: wire terminals 2 and 5
Cooling:..... wire terminals 3 and 5

Enclosure: plastic, material ABS,
colour pure white (similar RAL9010)

Dimensions: 127.5 x 75 x 28.6 mm

Installation:..... wall mounting or on in-wall flush box Ø 55 mm

Electrical connection: 0.14-2.5 mm²,
via terminal screws on circuit board

Protection class: II (according to EN 60730)

Protection type: IP 30 (according to IEC 529)

Standards: CE conformity,
EMC directive 89/336/EWG
low-voltage directive 73/23/EWG

Dimensional drawing

RHT

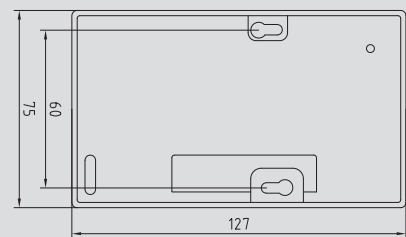
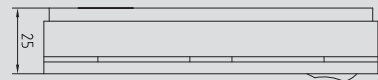
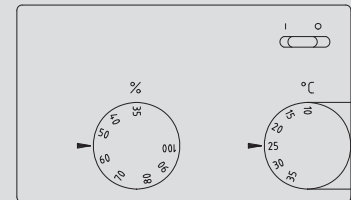

Connecting diagram

RHT

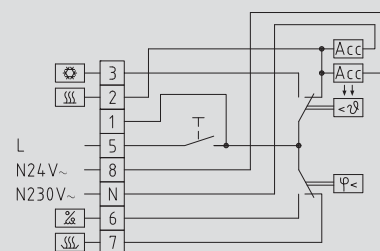

Room hygro-thermostat RHT:

Type/WG2	Setting range Temperature	Setting range Humidity	Features	Steps
RHT-1	+10°C...+35°C	35% r.H. ... 100% r.H.	External setting, main switch	1
Note: When mounting indoor room enclosures on in-wall flush boxes with horizontal fixing holes, adapter frame ARA 1.7 E must be included in the order. See accessories (last chapter).				

RH-2

Room hygromat mechanical, one-step, series Odin II

RH-2

APPLICATION:

For controlling and monitoring relative humidity in office and residential rooms, baths, labs, control cabinets, computer rooms, etc. Not applicable for aggressive gases.

TECHNICAL DATA:

- Power supply: 24...230 V AC
>24V in dry rooms only according to VDE 0110
- Setting range: 25...95% r.H.
- Switching capacity: dehumidifying 5 (0.2) A, min. 100 mA
(Contact load) humidifying 3 (0.2) A, min. 100 mA
- Contact: 1 changeover contact, (potential-free)
- Sensor element: plastic fibres
- Operating difference: ca. 4% r.H.
- Tolerance: max. 3% r.H.
- Enclosure temperature: 0°C...+40°C
- Enclosure: plastic, material ABS,
colour pure white (similar RAL9010)
- Dimensions: 95x97x30 mm
- Electrical connection: 0.14-2.5 mm² via terminal screws on circuit board
- Installation: wall mounting or on in-wall flush box Ø 55 mm,
base with 4 holes for mounting on vertically or
horizontally installed flush boxes, with
predetermined breaking point for on-wall cable entry
- Protection class: II (according to EN 60730)
- Protection type: IP 30 (according to IEC 529)
- Standards: CE conformity,
EMC directive 89/336/EWG,
low-voltage directive 73/23/EWG

FUNCTION:

- Humidifying: wire terminals 1 and 3
- Dehumidifying: wire terminals 1 and 2



RH-2U

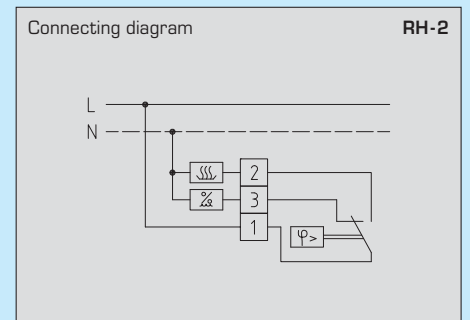
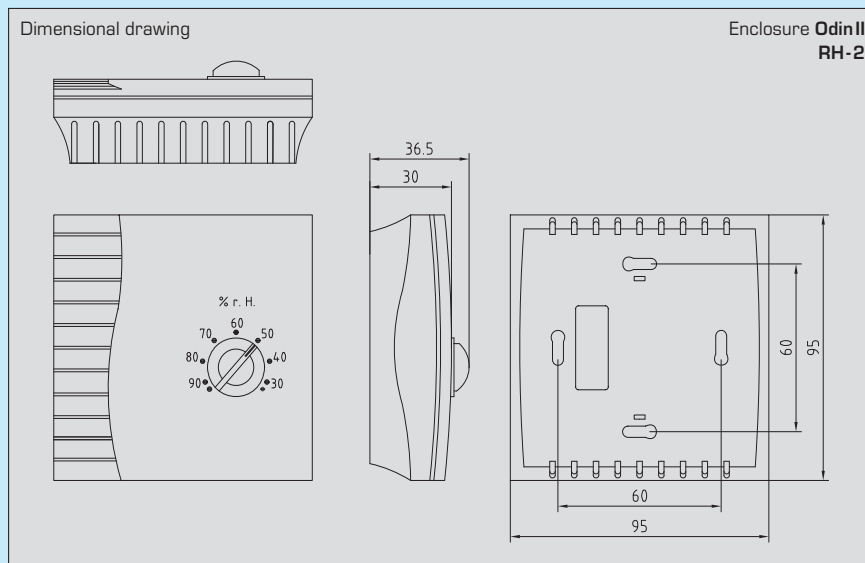

Room hygromat RH-2:

Type/WG2	Setting range Humidity	Steps	Hysteresis	Features
RH-2	25% r.H. ... 95% r.H.	1	ca. 4% r.H.	External setting
RH-2U	25% r.H. ... 95% r.H.	1	ca. 4% r.H.	Internal setting

1

HYGRASREG®

2

3

4

5

6

KH-30

Duct hygrostat, electronic,
one- and two-step



KH-30



KH-30
with display



APPLICATION:

For controlling and monitoring relative humidity in ventilation and air conditioning ducts, climatic test cabinets, swimming pools, greenhouses, etc., for the control of humidifying and dehumidifying equipment. Not applicable for aggressive gases.

TECHNICAL DATA:

- Power supply: 24 V AC/DC (230V AC optional)
Switching capacity 10 (6) A; 250V AC, min. 150 mA
Setting range: 0... 100% r.H.
Contact: potential-free single-pole changeover contact
Enclosure: plastic, material polyamide,
30% glass-globe-reinforced,
with quick-locking screws,
colour pure white (similar RAL9010)
Dimensions: 108 x 72.5 x 70 mm
Enclosure temperature: -10°C...+65°C
Operating difference: max. 2% r.H. (adjustable optional)
Flow rate: max. 8 m/s
Protective tube: metal, Ø 20 mm, rated length NL = 185 mm
Electrical connection: 0.14 - 1.5 mm² via terminal screws
Protection class: I (according to EN 60730)
Protection type: IP 65 (according to IEC 529)
Standards: CE conformity,
EMC directive 89/336/EWG,
low-voltage directive 73/23/EWG
Optional: 8-digit display, cutout 36x14 mm (WxH),
for displaying actual humidity/
adjusting humidity setpoint
ACCESSORIES: see last chapter

FUNCTION:

- Humidifying: **1 step:** wire contacts 4-5
When actual humidity falls more than
2% r.H. (hysteresis) below switching threshold S1,
the changeover contact switches to 4-5.
Dehumidifying: **1 step:** wire contacts 5-6
When actual humidity exceeds switching threshold
S1, the changeover contact switches to 5-6.

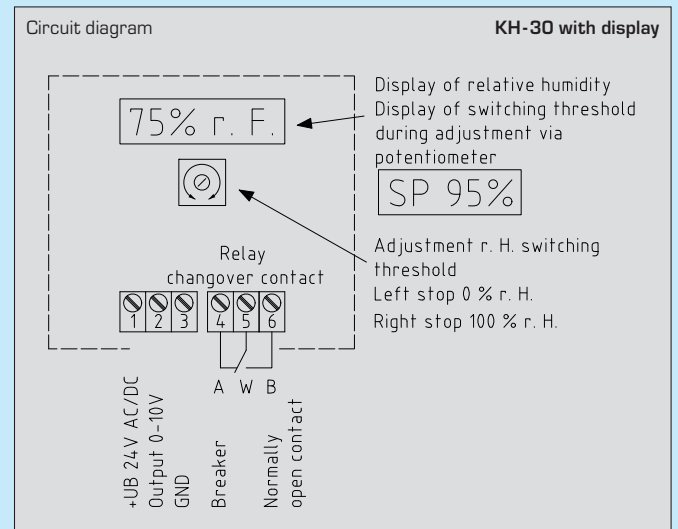
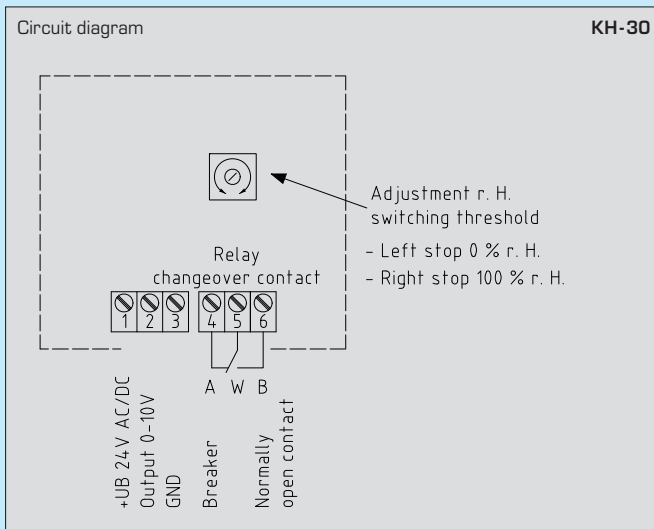
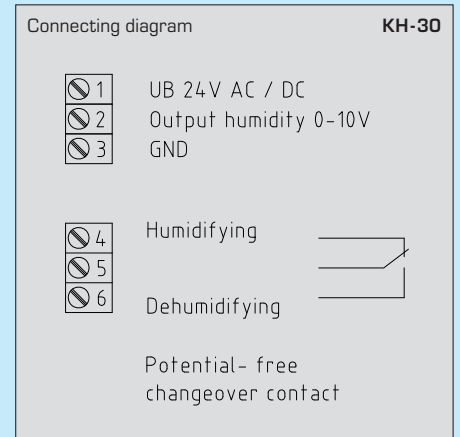
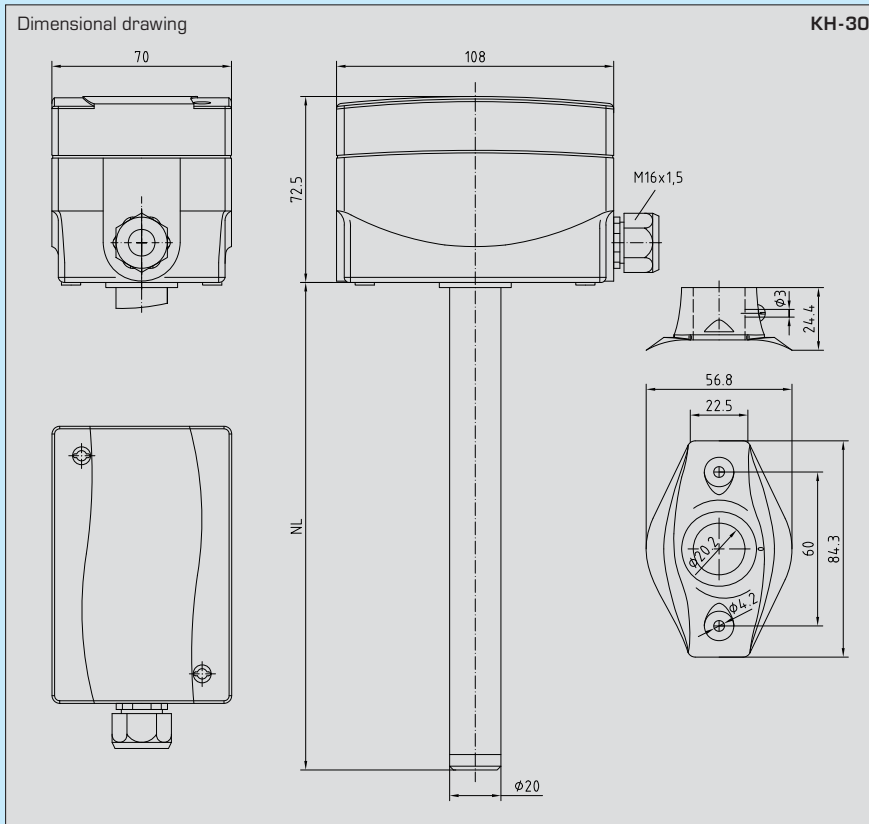

Duct hygrosstat KH-30, electronic, one- and two-step, including mounting flange:

Type/WG2	Setting range Humidity	Steps	Output	Features
KH-30 W	0 % r.H. ... 100 % r.H.	1	Changeover contact, 0 -10V	Internal setting
KH-30 W - Display	0 % r.H. ... 100 % r.H.	1	Changeover contact, 0 -10V	Internal setting, display
Optional:	For power supply by 230VAC 2-step version (two changeover contacts, potential-free)			
Accessories:	MF-16-K Mounting flange for KH, plastic, for duct installation WH-20 Wall bracket for KH for on-wall installation			

KH-10 / KH-20

Duct hygrostat, mechanical,
one- and two-step



KH

APPLICATION:

For controlling and monitoring relative humidity in ventilation and air conditioning ducts, climatic test cabinets, swimming pools, greenhouses, etc., for the control of humidifying and dehumidifying equipment. Not applicable for aggressive gases.

TECHNICAL DATA:

- Switching capacity: 15 (8) A; 24...250V AC, min. 150mA
(Contact load)
- Setting range: 35... 100% r.H.
- Contact: dustproof micro switch with
potential-free single-pole changeover contact
(gold-plated optional)
- Enclosure: plastic, material polyamide,
30% glass-globe-reinforced,
with quick-locking screws,
colour pure white (similar RAL9010)
- Dimensions: 108 x 72.5 x 70mm
- Enclosure temperature: -10 °C...+65 °C
- Operating difference: max. 4 % r.H.
- Flow rate: max. 8 m/s
- Sensor sleeve: brass, nickel-plated,
inserted length L = 220mm
- Electrical connection: 0.14 - 1.5mm² via terminal screws
- Protection class: I (according to EN 60730)
- Protection type: IP 65 (according to IEC 529)
- Standards: CE conformity,
EMC directive 89/336/EWG,
low-voltage directive 73/23/EWG
- ACCESSORIES: see last chapter

FUNCTION:

- Humidifying: **1 step:** wire contacts 1-4.
Switch points ON/OFF are ca. 2.5% r.H. above
respectively below the selected value.
- 2 steps:** wire contacts 1-4.
Connect 1st step of humidifier
to the right micro switch.
2nd step switchpoints (left switch) are
higher by the difference between steps.
- Dehumidifying: **1 step:** wire contacts 1-2.
Switch points ON/OFF are ca. 2.5% r.H. above
respectively below the selected value.
- 2 steps:** wire contacts 1-2.
Connect 2nd step of dehumidifier
to the right micro switch.
2nd step switchpoints (right switch) are
lower by the difference between steps.



KH-U



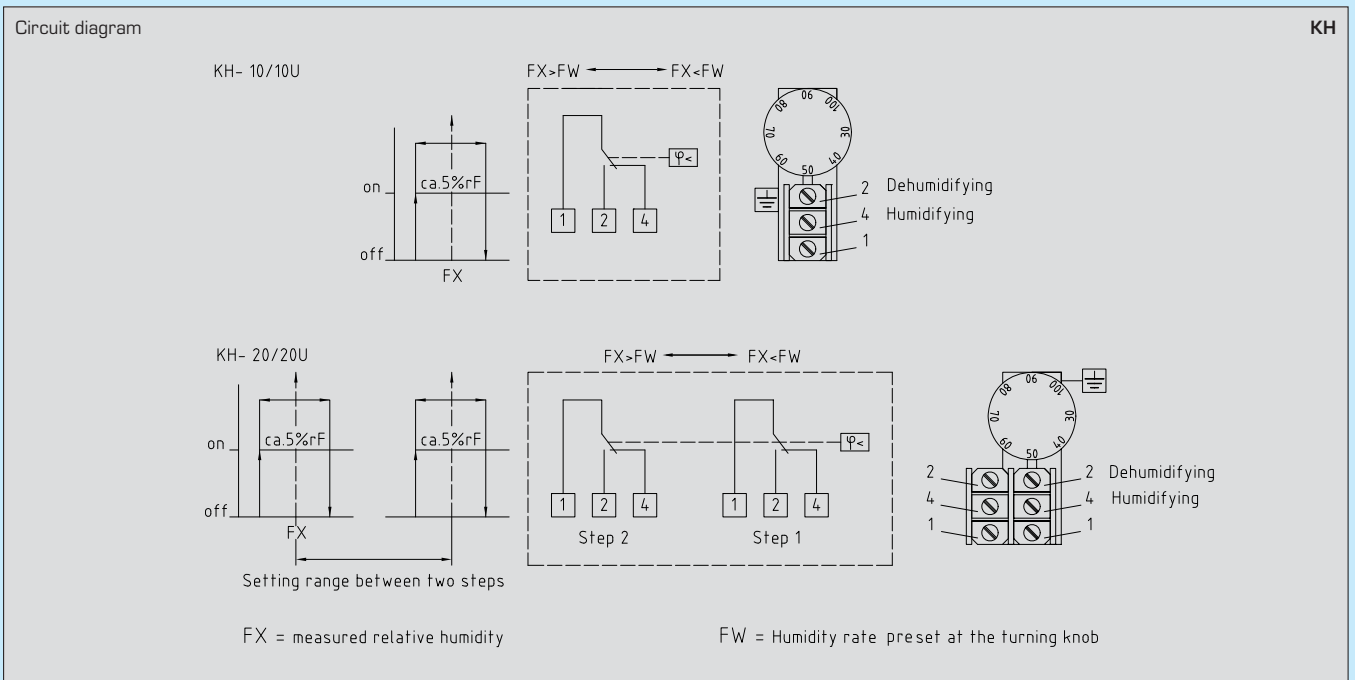
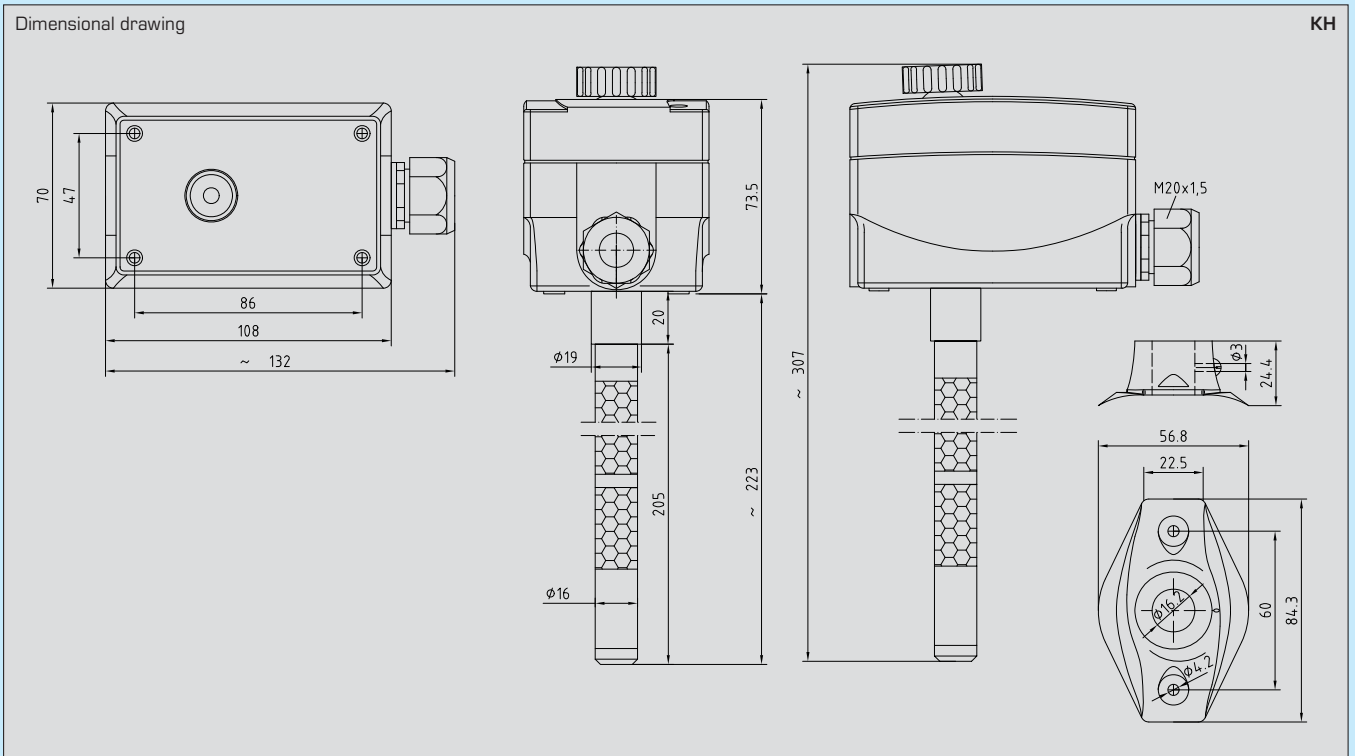

Duct hygrostat KH, mechanical, one- and two-step, including mounting flange:

Type/WG2	Setting range Humidity	Steps	Operating difference between steps	Features
KH-10	35 % r.H. ... 100 % r.H.	1		External setting
KH-10U	35 % r.H. ... 100 % r.H.	1		Internal setting
KH-20	35 % r.H. ... 100 % r.H.	2	3 % r.H. ... 18 % r.H.	External setting
KH-20U	35 % r.H. ... 100 % r.H.	2	3 % r.H. ... 18 % r.H.	Internal setting
Accessories:	MF-16-K Mounting flange for KH, plastic, for duct installation WH-20 Wall bracket for KH for on-wall installation			