

# 6

ZigBee™ compatible radio sensors

KYMASGARD®

ZigBee™ compatible radio controllers

KYMASREG®



## KYMASGARD® & KYMASREG®

### PORTFOLIO & FEATURES

- ZigBee™ compatible versions of all sensor and controller product lines
- With switching or bus output
- WAP2 authentication for optimum data security
- High electromagnetic compatibility

### BENEFITS

- Reduced installation and wiring effort
- Utmost flexibility in placing sensors since laying of cables unnecessary
- Simple mounting at representative measuring points
- Optional with hybrid solar-powered radio module with extended lifetime
- Maintenance-free for 5 years due to minimum transmitting power
- Cost-effective system solutions
- Flexible integration into already installed systems



### FIELDS OF APPLICATION

- Vast building complexes and company premises
- Renovation, modernisation, and extension of buildings and factories
- Historical buildings and churches
- Large museums, administration and hospital centres



# KYMASGARD® KYMASREG®

Temperature, humidity, and light intensity radio sensors (transmitters)  
and radio frequency receivers



## APPLICATION:

Radio sensors are used for transmitting measurands between transmitter and receiver without necessitating a physical connection (wiring) between both locations.

These sensors are practical for retrofitting in the sector of building renovation and extension or for positioning at measuring points in arbitrary locations as well as for integration into already existing or new systems.

The radio transmitter units are based on the ZigBee™ following system ZEBRA (ZigBee Enabled Board for Radio Applications). The reach is considerably increased by hopping compared to conventional systems. Participants can forward information packets to other network nodes and so, multiply the range of reach. The battery voltage of each individual participant is continuously monitored.

© ZigBee™ is a registered trademark of ZigBee-Alliance.

## AN OVERVIEW OF SOME BENEFITS:

- Bi-directionality of data communication, i.e. measured data is automatically sent from the measuring points in periodical intervals, or can be manually queried.
- Flexible development of larger networks, direct or via "sub-networks" (optional).
- Bridging of greater distances or coverage of areas of no reception via hops, which means, routers forward data directed to the next node (hop).
- If a measuring point is located in an area of no reception, it still can be reached by using routers.
- Upon installation, automatic verification and selection of a free radio channel in the license fee-free frequency band.
- Coded data packets .
- Automatic acknowledgement of received packets, which is necessary for safety of data transmission.
- Controlled integration of additional nodes into the radio network and refusal of connection of illegal nodes.
- Utilisation of a standardised transmission protocol, implying availability and expandability for many years.
- Automatic monitoring of battery capacity.
- Optional interfaces to established wired data networks e.g. RS232, RS485, USB, Ethernet, etc.

## TECHNICAL DATA:

Power supply:..... battery-operated,  
optional with solar cell (maintenance-free), Goldcup

Transmitting power:..... ca. 1 mW

Number of participants:..... up to 254

Operating frequency:..... 2.4...2.45GHz

Reach inside buildings:..... up to 50m  
(depending on local circumstances)

Reach outdoors:..... ca. 200m

Output:..... 0 -10V or RS485, or bus

Measuring range, temperature:.. 0...+ 50°C (room and outdoor sensors)  
0...+ 100°C (duct and screw-in sensors)

Accuracy, temperature: ..... ± 0.3K

Measuring range, humidity:..... 0...100% r.H.

Accuracy, humidity:..... ± 3% r.H.

Measurable quantities:..... humidity, temperature, light intensity,  
angle of turn (position of potentiometer),  
digital signals (switches, contacts)

Standards: ..... CE conformity, electromagnetic compatibility  
according to EN 61 326 + A1 + A2,  
EMC directive 89/336/EWG  
low-voltage directive 73/23/EWG



RTF-FSE  
(solar cell)



RTF-FSE-P  
(solar cell)



RTF-FSE-PD  
(solar cell)



RTF-FSE-PDT  
(solar cell)

# RTF-FSE

Room temperature radio sensor and measuring transducer on-wall, series Odin II



## APPLICATION:

Room temperature sensor in shapely plastic enclosure. It is used for detection of temperature in closed dry rooms, in apartments, in office and business facilities.

## TECHNICAL DATA:

Measuring range:..... 0...+ 50 °C  
 Sensor/output: ..... radio signal  
 Process connection: ..... by screws  
 Enclosure:..... plastic, material ABS,  
 colour pure white (similar RAL9010)  
 Dimensions: ..... 95x97x30 mm  
 Installation:..... on in-wall flush box Ø 55 mm with 4 holes for mounting  
 on vertically or horizontally installed flush boxes  
 Humidity:..... max. 90% r.H., non-precipitating air  
 Protection class: ..... III (according to EN 60730)  
 Protection type:..... IP 30 (according to IEC 529)  
 Standards: ..... CE conformity, electromagnetic compatibility  
 according to EN 61326 + A1 + A2,  
 EMC directive 89/336/EWG  
 low-voltage directive 73/23/EWG  
 Radio receiver: ..... see end of chapter  
 Basic device: ..... see pages 62-69



RTF-FSE  
(standard)



RTF-FSE-P  
(standard)



RTF-FSE-PD  
(standard)



RTF-FSE-PD4  
(standard)

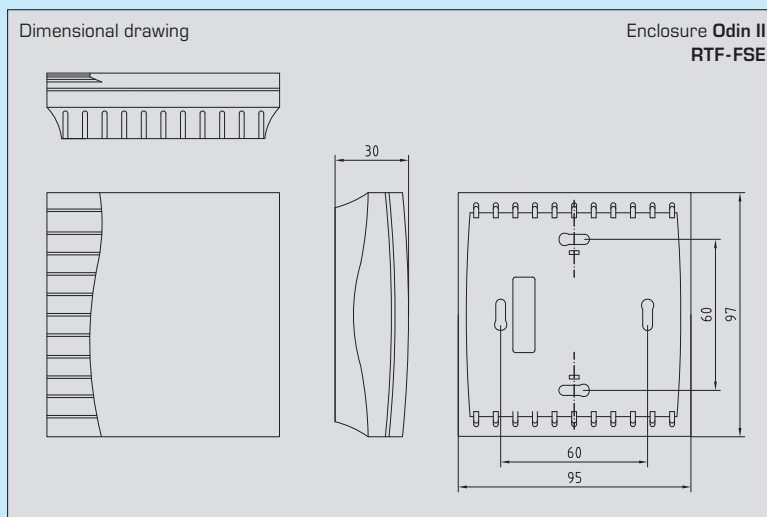

Room temperature radio sensor RTF-FSE, with/without operating elements:

Type/WG3	Operating elements	Measuring range Temperature	Output Temperature
RTF-FSE	-	0...+ 50 °C	Radio signal
RTF-FSE-P	Potentiometer	0...+ 50 °C	Radio signal
RTF-FSE-PD4	Potentiometer, turn switch	0...+ 50 °C	Radio signal
RTF-FSE-PD4T	Potentiometer, turn switch, pushbutton	0...+ 50 °C	Radio signal
Optional:	Solar module (enclosure with solar cell)		

# ETF 1-FSE including brass immersion sleeve, nickel-plated ETF 2-FSE including stainless steel immersion sleeve



## Screw-in/immersion temperature radio sensor

### APPLICATION:

Built-in temperature sensors are electric contact thermometers for installation in pipes, tanks, and vessels for measuring temperatures of liquids and gases. Screw-in resistance thermometers with plastic enclosure and straight protective tube. For aggressive media, stainless steel immersion sleeves are to be used. Applications in piping, in heating technology, in storage tanks, district heat compact stations, warm and cold water systems, in oil and lubricant circulating systems, in mechanical, apparatus and plant engineering, as well as in the entire industrial sector.

ETFx-FSE  
(standard)

### TECHNICAL DATA:

- Measuring range: ..... 0...+100°C
- Sensoren/output: ..... radio signal
- Process connection: ..... screwed socket with 1/2" pipe thread
- Immersion sleeve: ..... ETF1 brass, nickel-plated, 1/2" pipe thread,  
wrench size 22 mm, Ø=8 mm  
ETF2 stainless steel, 1.4571, V4A, 1/2" pipe thread,  
wrench size 27 mm, Ø=8 mm
- Protective tube: ..... stainless steel, 1.4571, V4A, Ø=6 mm
- Connecting head: ..... plastic, material polyamide, 30% glass-globe-reinforced,  
with quick-locking screws,  
colour pure white (similar RAL9010)  
ambient temperature -20/+100°C
- Dimensions: ..... 72x64x39.4 mm
- Max. pressure: ..... ETF1 brass immersion sleeves 10 bar  
ETF2 stainless steel immersion sleeves 40 bar
- Humidity: ..... < 95% r.H.
- Protection class: ..... III (according to EN 60730)
- Protection type: ..... IP 65 (according to IEC 529)
- Standards: ..... CE conformity, electromagnetic compatibility  
according to EN 61326 + A1 + A2,  
EMC directive 89/336/EWG  
low-voltage directive 73/23/EWG
- Radio receiver: ..... see end of chapter
- Basic device: ..... see pages 28-29



ETFx-FSE  
(solar cell)

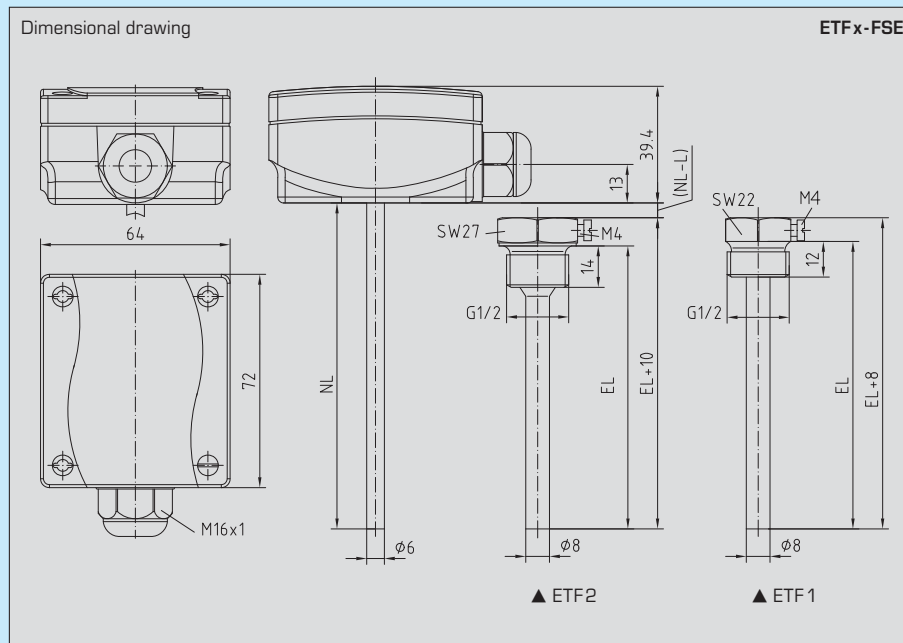

Screw-in/immersion temperature radio sensor ETF 1-FSE, including brass immersion sleeve, 1/2" pipe thread,  
Screw-in/immersion temperature radio sensor ETF 2-FSE including stainless steel immersion sleeve, 1/2" pipe thread:

Type/WG3 - EL	50 mm	100 mm	150 mm	200 mm	250 mm	300 mm	400 mm
ETF 1 - FSE	•	•	•	•	•	•	•
ETF 2 - FSE	•	•	•	•	•	•	•
Optional:	Solar module (enclosure with solar cell)						
Please indicate with your order:	Type and length of immersion sleeve e.g. ETF 1-FSE, 150 mm; ETF 2-FSE, 250 mm						

1

2

3

4

5

KYMASGARD®  
6

# KTF 1-FSE including mounting flange

Duct temperature radio sensor / air duct temperature radio sensor

## APPLICATION:

Duct resistance thermometer with connection enclosure made of impact-resistant plastic. Particularly used for airflows, for the detection of temperatures in gaseous media, e.g. in ventilation and air conditioning ducts.

## TECHNICAL DATA:

Measuring range:..... 0...+100°C  
 Sensoren/output:..... radio signal  
 Protective tube:..... stainless steel, 1.4571, V4A, Ø=6 mm (optional perforiert)  
 Connecting head:..... plastic, material polyamide, 30% glass-globe-reinforced, with quick-locking screws, colour pure white (similar RAL9010), ambient temperature -20/+100°C  
 Dimensions:..... 72x64x39.4 mm  
 Process connection:..... by mounting flange (included in the scope of delivery), plastic, (galvanised steel optional, see accessories)  
 Humidity:..... < 95% r.H.  
 Protection class:..... III (according to EN 60730)  
 Protection type:..... IP 65 (according to IEC 529)  
 Standards:..... CE conformity, electromagnetic compatibility according to EN 61326 + A1 + A2, EMC directive 89/336/EWG low-voltage directive 73/23/EWG  
 Radio receiver:..... see end of chapter  
 Basic device:..... see page 49

KTF 1-FSE (standard)

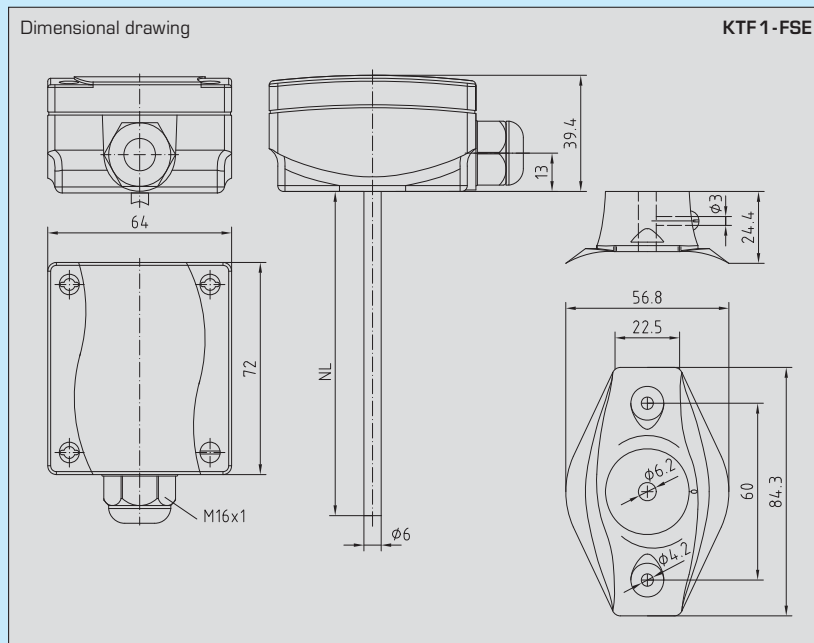

KTF 1-FSE (solar cell)



## Duct temperature radio sensor KTF 1-FSE, including mounting flange:

Type/WG3 - EL	50 mm	100 mm	150 mm	200 mm	250 mm	300 mm	400 mm
KTF 1 - FSE	•	•	•	•	•	•	•
Optional:	Solar module (enclosure with solar cell)						
Please indicate with your order:	Type and length of immersion sleeve e.g. KTF 1-FSE, 150 mm; KTF 1-FSE, 250 mm						

# ATF 2 -FSE

Outside temperature radio sensor /  
wet room temperature radio sensor



## APPLICATION:

Outside wall resistance thermometer / weather sensor with enclosure made of impact-resistant plastic for the detection of outside temperatures, temperatures in wet room areas, e.g. as weather sensor for installation on outside walls, in cold storage buildings and green houses, in halls, in the industrial sector and in agriculture. Installation in outdoor areas preferably at the north side of a building or in a protected place. In case of direct solar radiation, a sunshade should be used.

## TECHNICAL DATA:

Measuring range:..... 0...+50 °C  
 Sensoren/output:..... radio signal  
 Enclosure:..... plastic, material polyamide,  
 30% glass-globe-reinforced,  
 with quick-locking screws,  
 colour pure white (similar RAL9010)  
 Dimensions:..... 72x64x39.4 mm  
 Humidity:..... <95% r.H.  
 Protection class:..... III (according to EN 60730)  
 Protection type:..... IP 65 (according to IEC 529)  
 Standards: ..... CE conformity, electromagnetic compatibility  
 according to EN 61326 + A1 + A2,  
 EMC directive 89/336/EWG  
 low-voltage directive 73/23/EWG  
 Radio receiver:..... see end of chapter  
 Basic device: ..... see page 22

ATF 2-FSE  
(standard)



ATF 2-FSE  
(solar cell)

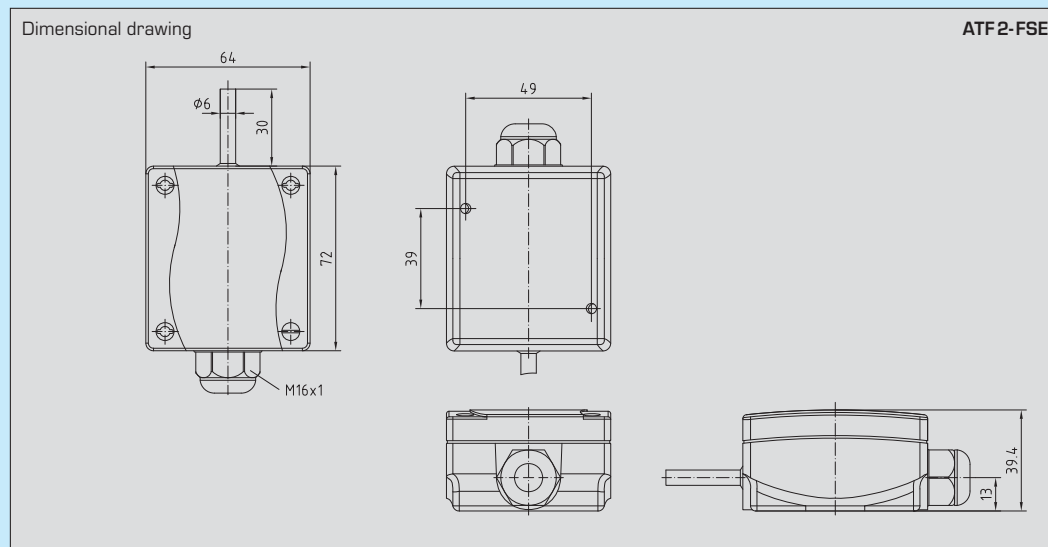

## Outside temperature radio sensor ATF2-FSE:

Type/WG3	Measuring range Temperature	Output Temperature
ATF 2-FSE	0...+50 °C	Radio signal
Optional:	Solar module (enclosure with solar cell)	
Accessories:	<b>SS-01</b> Sunshade and ball-game protection	

# RFF-FSE RFTF-FSE

Room humidity and temperature radio sensors  
on-wall, calibrateable, series Odin II



## APPLICATION:

**FOR HVAC SECTOR, ACCURACY 3 % R.H.**

The calibrateable humidity/temperature sensor measures the relative humidity and temperature of air and other non-aggressive gases. It is used in refrigeration, air conditioning, and clean room technology, in residential rooms, offices, hotels, technical rooms, meeting rooms and convention centres.

## TECHNICAL DATA:

- Sensors: ..... capacitive humidity sensor, temperature sensor NTC, dew-proof, small hysteresis, high long-term stability
- Measuring range, humidity: ..... 0...100% r.H.
- Operating range, humidity: ..... 10...90% r.H.
- Deviation, humidity: .....  $\pm 3\%$  r.H. (40...60%); at +20 °C, otherwise  $\pm 5\%$  r.H.
- Measuring range, temperature: .. 0...+ 50 °C
- Operating range, temperature: .. 0...+ 50 °C
- Deviation, temperature: .....  $\pm 0.8\text{K}$  (RFF/RFTF-U),  $\pm 0.8\text{K}$  (RFF/RFTF-I) at 20 °C, under standard conditions
- Output: ..... radio signal
- Ambient temperature: ..... storage -25...+50 °C, operation -5...+55 °C
- Enclosure: ..... plastic, material ABS, colour pure white (similar RAL9010)
- Dimensions: ..... 79 x 81 x 26 mm
- Installation: ..... wall mounting on in-wall flush box  $\varnothing 55$  mm with 4 holes for mounting on vertically or horizontally installed flush boxes
- Long-term stability: .....  $\pm 1\%$  per year
- Protection class: ..... III (according to EN 60730)
- Protection type: ..... IP30 (according to IEC 529)
- Standards: ..... CE conformity, electromagnetic compatibility according to EN 61326 + A1 + A2, EMC directive 89/336/EWG low-voltage directive 73/23/EWG
- Radio receiver: ..... see end of chapter
- Basic device: ..... see pages 132-135



RFF-FSE  
RFTF-FSE  
(standard)



RFF-FSE  
RFTF-FSE  
(solar cell)

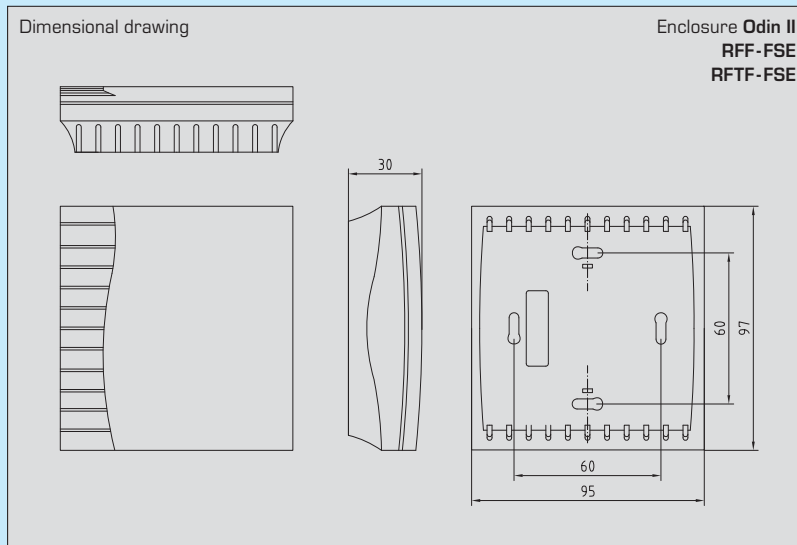

Room temperature radio sensor RFF-FSE,  
Room humidity and temperature radio sensor RFTF-FSE:

Type/WG3	Measuring range Humidity	Measuring range Temperature	Output Humidity	Output Temperature
RFF-FSE	0...100% r.H.	-	Radio signal	-
RFTF-FSE	0...100% r.H.	0...+ 50 °C	Radio signal	Radio signal
Optional:	Solar module (enclosure with solar cell)			

# AFF-FSE AFTF-FSE

On-wall humidity and temperature radio sensors  
calibrateable



## APPLICATION:

For HVAC sector, accuracy 3 % r.H.

The calibrateable humidity/temperature sensor measures relative humidity and temperature of air and other non-aggressive gases. It is used in building automation, refrigeration, air conditioning, ventilation, and clean room technology, in greenhouses and halls.

## TECHNICAL DATA:

- Sensors: ..... capacitive humidity sensor, temperature sensor NTC, dew-proof, small hysteresis, high long-term stability
- Sensor protection: ..... membrane filter, exchangeable
- Measuring range, humidity: ..... 0...100% r.H.
- Operating range, humidity: ..... 10...90% r.H.
- Deviation, humidity: ..... ±2% r.H. (20...90%); at +20°C, otherwise ±3% r.H.
- Measuring range, temperature: .. -20...+80°C
- Operating range, temperature: .. -20...+80°C
- Deviation, temperature: ..... depending on place of installation and position
- Output: ..... radio signal
- Ambient temperature: ..... storage -25...+50°C, operation -5...+55°C
- Enclosure: ..... plastic, material polyamide, 30% glass-globe-reinforced, with quick-locking screws, colour pure white (similar RAL9010)
- Dimensions: ..... 108x70x73.5mm
- Process connection: ..... by screws
- Long-term stability: ..... ± 1% per year
- Protection class: ..... III (according to EN 60730)
- Protection type: ..... IP 65 (according to IEC 529)
- Standards: ..... CE conformity, electromagnetic compatibility according to EN 61326+A1+A2, EMC directive 89/336/EWG low-voltage directive 73/23/EWG
- Radio receiver: ..... see end of chapter
- Basic device: ..... see pages 122-125

AFF-FSE  
AFTF-FSE  
(standard)



AFF-FSE  
AFTF-FSE  
(solar cell)

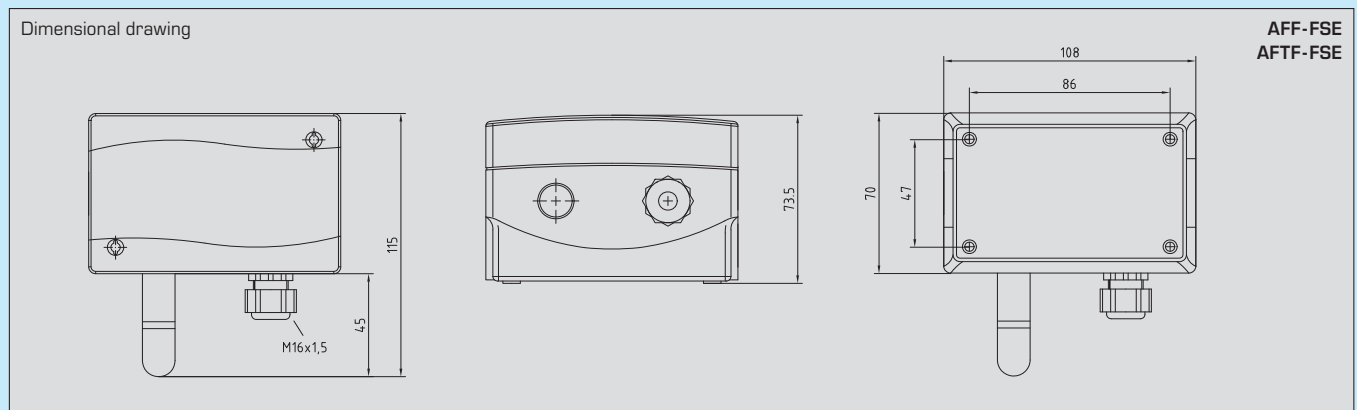

AFF-FSE  
AFTF-FSE

On-wall temperature radio sensor AFF-FSE,  
On-wall humidity and temperature radio sensor AFTF-FSE:

Type/WG3	Measuring range Humidity	Measuring range Temperature	Output Humidity	Output Temperature
AFF-FSE	0...100% r.H.	-	Radio signal	-
AFTF-FSE	0...100% r.H.	-20...+80°C	Radio signal	Radio signal
Optional:	Solar module (enclosure with solar cell)			

1

2

3

4

5

KYMASGARD®  
6

## Outdoor light intensity radio sensor / twilight radio sensor

AHKF-FSE  
(standard)

### APPLICATION:

The light intensity radio sensor measures the luminous intensity and is used to control luminaries, lighting systems, Venetian blinds and canvas blinds, etc. Applications in monitoring lighting conditions at workplaces, in greenhouses, storage halls, workshops, and corridors, in outdoor areas, in industrial halls, in offices, in residential and in business facilities. It is used for daylight-dependant light-constant control, as light intensity or twilight sensor and for controlling sunshade equipment to avoid unnecessary heating-up of rooms.

### TECHNICAL DATA:

Sensor: ..... photodiode  
 Measuring ranges: ..... 0...500 Lux, 1 kLux, 20 kLux, 60 kLux,  
 (other ranges optional, arbitrary, e.g. 100 kLux)  
 Output: ..... radio signal  
 Ambient temperature: ..... -10...+50 °C  
 Measuring error: ..... <10 % of final value  
 Enclosure: ..... plastic, material polyamide,  
 30% glass-globe-reinforced,  
 with quick-locking screws,  
 colour pure white (similar RAL9010)  
 Dimensions: ..... 72 x 64 x 39.4 mm  
 Installation: ..... on-wall  
 Protection class: ..... III (according to EN 60 730)  
 Protection type: ..... IP 65 (according to IEC 529)  
 Standards: ..... CE conformity, electromagnetic compatibility  
 according to EN 61 326 + A1 + A2,  
 EMC directive 89/336/EWG  
 low-voltage directive 73/23/EWG  
 Radio receiver: ..... see end of chapter  
 Basic device: ..... see page 166

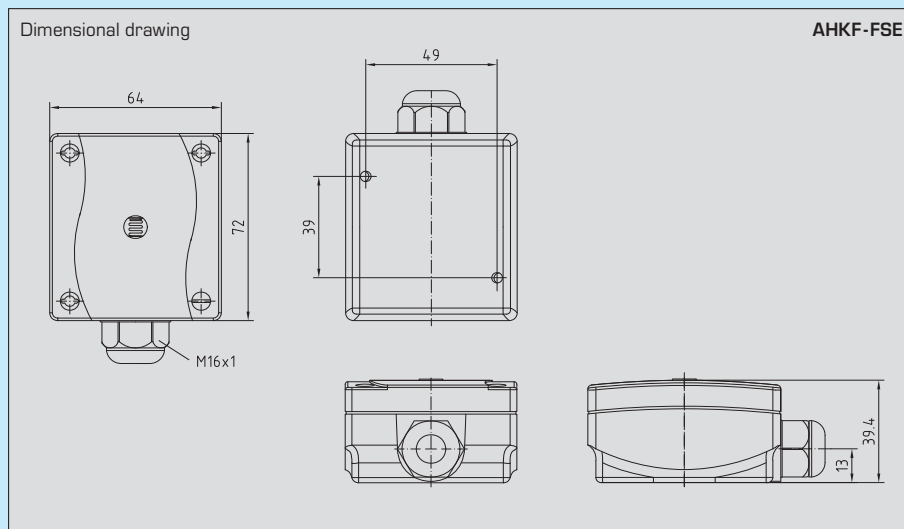

### Outdoor light intensity radio sensor AHKF-FSE:

Type / WG3	Measuring range Light intensity	Output Light intensity
AHKF-0.5-FSE	0 ... 500 Lux	Radio signal
AHKF-20-FSE	0 ... 20.000 Lux	Radio signal
AHKF-60-FSE	0 ... 60.000 Lux	Radio signal
Optional:	Solar module (enclosure with solar cell)	

# R-FEM

## Room radio receiver on-wall, series Odin II



R-FEM

### APPLICATION:

Used to convert the radio signal into an electric value or actuator response. A great advantage of KYMASREG radio receivers is, that up to 254 KYMASGARD radio transmitters can be sending to one receiver.

### TECHNICAL DATA:

- Number of participants: ..... up to 254
- Output: ..... 0 - 10V or RS485 or bus
- Enclosure: ..... plastic, material ABS,  
colour pure white (similar RAL9010)
- Dimensions: ..... 95x97x30mm
- Electrical connection: ..... 0.14 - 1.5mm<sup>2</sup> via terminal screws
- Installation: ..... on in-wall flush box Ø 55 mm, base with 4 holes for mounting  
on vertically or horizontally installed flush boxes, with predetermined  
breaking point for on-wall cable entry
- Humidity: ..... < 95% r.H., non-precipitating air
- Protection class: ..... III (according to EN 60730)
- Protection type: ..... IP 30 (according to IEC 529)
- Standards: ..... CE conformity, electromagnetic compatibility  
according to EN 61326 + A1 + A2,  
EMC directive 89/336/EWG  
low-voltage directive 73/23/EWG
- ACCESSORIES: ..... antenna ANT-FEM (see page 209)

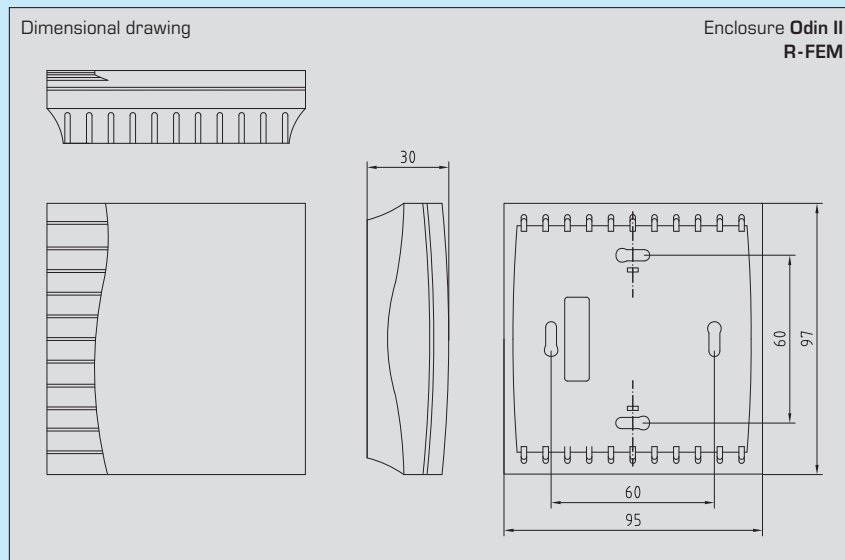

### Room radio receiver R-FEM:

Type/WG3	Features, output
<b>R-FEM-RS485</b>	Receiver with serial interface RS 485 (for up to 254 radio transmitters, parallel) e.g. for the connection of KYMASGARD radio sensors to SAIASIA®-S-Bus-controllers
<b>R-FEM-V</b>	Radio amplifier (for up to 254 radio transmitters, parallel)
<b>R-FEM-T</b>	Receiver for temperature control (room thermostat) for heating / cooling, 1x changeover contact, potential-free
<b>R-FEM-F</b>	Receiver for humidity control (room hygostat), 1x changeover contact, potential-free

# HS-FEM ANT-FEM

Radio receiver for top-hat rail installation  
and antenna for radio receivers



HS-FEM

**APPLICATION:**

Used to convert the radio signal into an electric value or actuator response. A great advantage of KYMASREG radio receivers is, that up to 254 KYMASGARD radio transmitters can be sending to one receiver.

**TECHNICAL DATA:**

- Power supply:..... 24V AC/DC
- Transmitting power:..... ca. 1 mW
- Number of participants:..... up to 254
- Operating frequency:..... 2.4...2.45 GHz
- Reach inside buildings:..... up to 50 m  
(depending on local circumstances)
- Reach outdoors:..... ca. 200 m
- Output: ..... 4 analog outputs: ..... 0 - 10V  
2 relay outputs: ..... 230V/6 A
- Enclosure:..... plastic, material polycarbonate,  
colour signal green [similar RAL6029]
- Dimensions:..... 5 TE (75 x 75 x 53 mm)
- Electrical connection: ..... 0.2 - 2.5 mm<sup>2</sup>
- Installation:..... on DIN top hat rail
- Protection class: ..... II (according to EN 60730)
- Protection type:..... IP 20 (according to IEC 529)
- Standards:..... CE conformity, electromagnetic compatibility  
according to EN 61326 + A1 + A2,  
EMC directive 89/336/EWG  
low-voltage directive 73/23/EWG
- ACCESSORIES: ..... antenna ANT-FEM



ANT-FEM

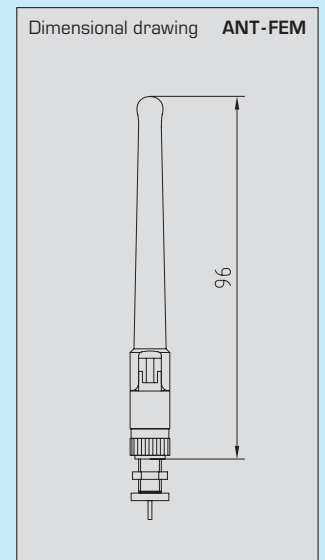
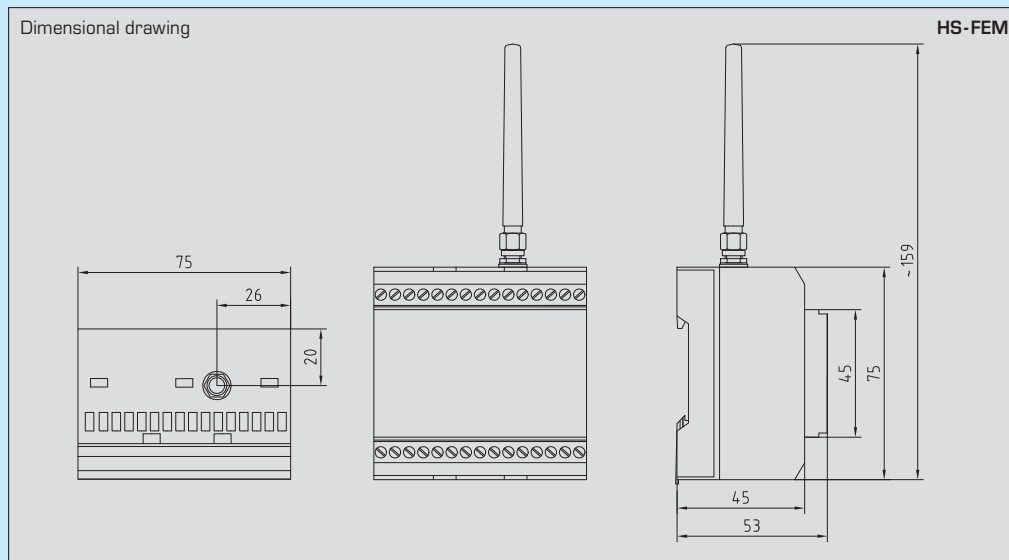

**Top hat rail radio receiver HS-FEM and antenna ANT-FEM:**

Type/WG3	Features, output
<b>HS-FEM-RS485</b>	Receiver with serial interface RS 485 (for up to 254 radio transmitters, parallel), e.g. for the connection of KYMASGARD radio sensors to SAIA®-S-Bus-controllers
<b>HS-FEM-4A2R</b>	Receiver for connection to individual room controllers, 4 analog outputs 0 - 10V, 2 relay outputs 230V/6 A
<b>ANT-FEM</b>	Antenna for radio receivers HS-FEM and R-FEM

1

2

3

4

5

KYMASREG®

6

# Accessories

Immersion sleeves  
made of stainless steel  
and brass, nickel-plated



Stainless steel  
immersion sleeve  
**TH-VA/xx**

with neck tube  
**TH-VA/xx/90**

Brass  
immersion sleeve  
**TH-ms/xx**



Dimensional drawing **TH-VA/xx**

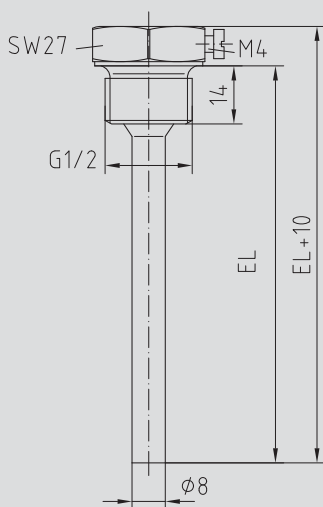

Dimensional drawing **TH-VA/xx/90**

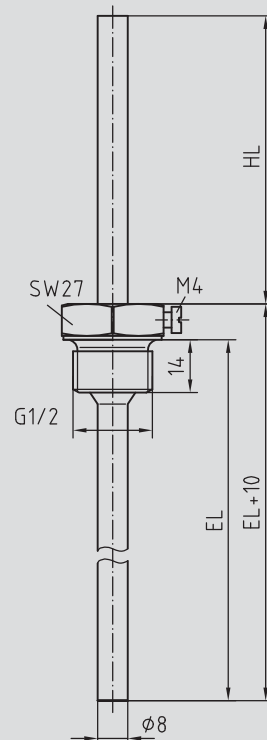

Dimensional drawing **TH-ms/xx**

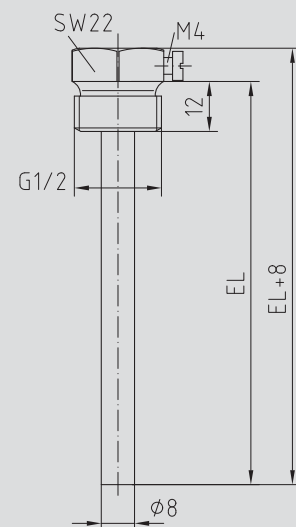

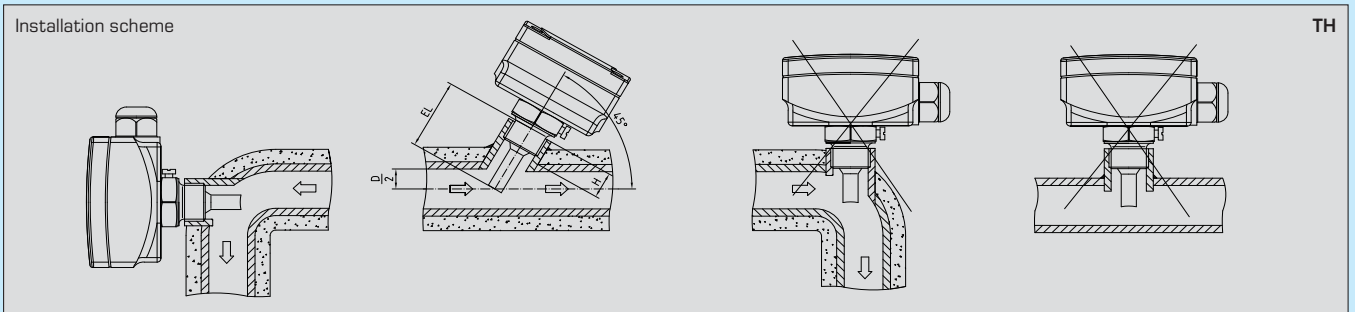

### INFORMATION FOR PLANNING AND INSTALLATION

#### Permissible approach velocities (flow rates) for crosswise approached protective tubes in water.

The protective tube is caused to vibrate by the approaching flow.

If the specified approach velocity is exceeded even by a marginal amount, a negative influence on the lifetime of the protective tube may result (material fatigue).

Please observe the permissible approach velocities for stainless steel protective tubes (see diagram TH-VA) as well as for brass protective tubes (see diagram TH-ms).

Gas discharges and pressure surge must be avoided as such have negative influence on lifetime or damage protective tubes.

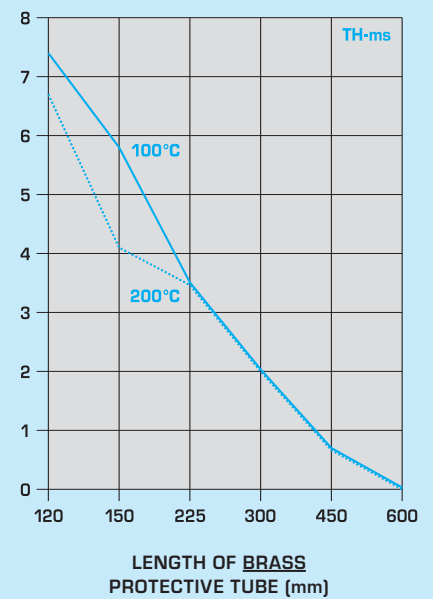
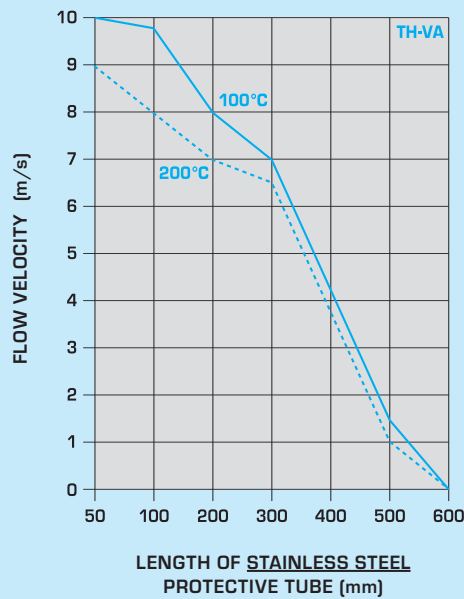

### Immersion sleeves TH

For screw-in temperature sensors ETF 1/2 and screw-in measuring transducers ETM 1/2, 1/2" pipe thread:

Type/WG 1	Material $p_{max}$ (static) / $T_{max}$	Inserted length (EL)							
		50 mm	100 mm	150 mm	200 mm	250 mm	300 mm	400 mm	
TH-ms/xx	Brass nickel-plated 10 bar / 150 °C	•	•	•	•	•	•	•	
TH-VA/xx	Stainless steel VA 1.4571 40 bar / 600 °C	•	•	•	•	•	•	•	
TH-VA/xx/90 incl. neck tube (90 mm)	Stainless steel VA 1.4571 40 bar / 600 °C	•	•	•	•	•	•	•	
Ordering example:	TH-ms/100 (brass immersion sleeve without neck tube, EL = 100 mm, Ø = 8 mm) TH-VA/200 (stainless steel immersion sleeve without neck tube, EL = 200 mm, Ø = 8 mm) TH-VA/300/90 (stainless steel immersion sleeve with neck tube, EL = 300 mm / HL = 90 mm, Ø = 8 mm)								

### Immersion sleeves TH

For screw-in temperature controllers ETR:

Type/WG2	Immersion sleeve Ø	Thread Ø	Inserted length EL	Material	$p_{max}$ (static)	$T_{max}$
TH-ms-01	Ø 12 x 1	1/2"	120 mm	Brass, nickel-plated	10 bar	150 °C
TH-VA-02	Ø 12 x 1	1/2"	120 mm	Stainless steel VA 1.4571	40 bar	150 °C
TH-ms-16	Ø 10 x 0.5	1/2"	120 mm	Brass, nickel-plated	10 bar	150 °C
TH-ms-16/14	Ø 10 x 0.5	1/2"	120 mm	Brass, nickel-plated	10 bar	150 °C
TH-VA-17	Ø 10 x 0.8	1/2"	120 mm	Stainless steel VA 1.4571	40 bar	150 °C
TH-VA-17/14	Ø 10 x 0.8	1/2"	120 mm	Stainless steel VA 1.4571	40 bar	150 °C
TH-ms-30/14	Ø 8 x 0.5	1/2"	120 mm	Brass, nickel-plated	10 bar	150 °C
TH-VA-41/14	Ø 16 x 1.0	1/2"	120 mm	Stainless steel VA 1.4571	40 bar	150 °C
TH-VA-31/14	Ø 9 x 1.0	1/2"	120 mm	Stainless steel VA 1.4571	40 bar	150 °C
TH-ms-40/14	Ø 16 x 0.5	1/2"	120 mm	Brass, nickel-plated	10 bar	150 °C

Other inserted lengths are available upon request (e.g. 200 mm).